



---

## Specifications of basic booths ( System panels booth )

- Specifications of basic booths ( P1 )
- Top View of Basic Booth ( P1 )
- The details of system panels ( P2 )
- Specification and notes ( P2 )

---

## Packaged Booth Information

- Schedule ( P3 )
- Packaged Booth Display • 1 booth ( P4, P5 )
- Packaged Booth Display • 2 booths ( P6, P7 )
- Packaged Booth Display • 3 booths ( P8, P9 )

---

## Optional Tool ( P10- P13 )

---

## Color Sample ( P14 )

---

## Order Form

- Packaged Booth Display Order Form ( P15 )
- Optional Tool Order Form ( P16 )

For further information and request on "System Panel" and "Package Booth",  
please contact the following company.

### **Ten Co.,LTD.**

Morimitu Shinkou Bldg.9F, 5-9, Kotobuki, 1-chome, Taitou-ku, Tokyo 111-0042, JAPAN

Fax : +81-3-3842-7720

E-mail : jasis@teninc.co.jp

★ I apologize for bothering you, but please contact us by e-mail.

## Specifications of basic booths ( System panels booth )

The specifications of system panels which we prepare as the basic booths in the system panels booth area are as follow.

### ● Specifications of basic booths

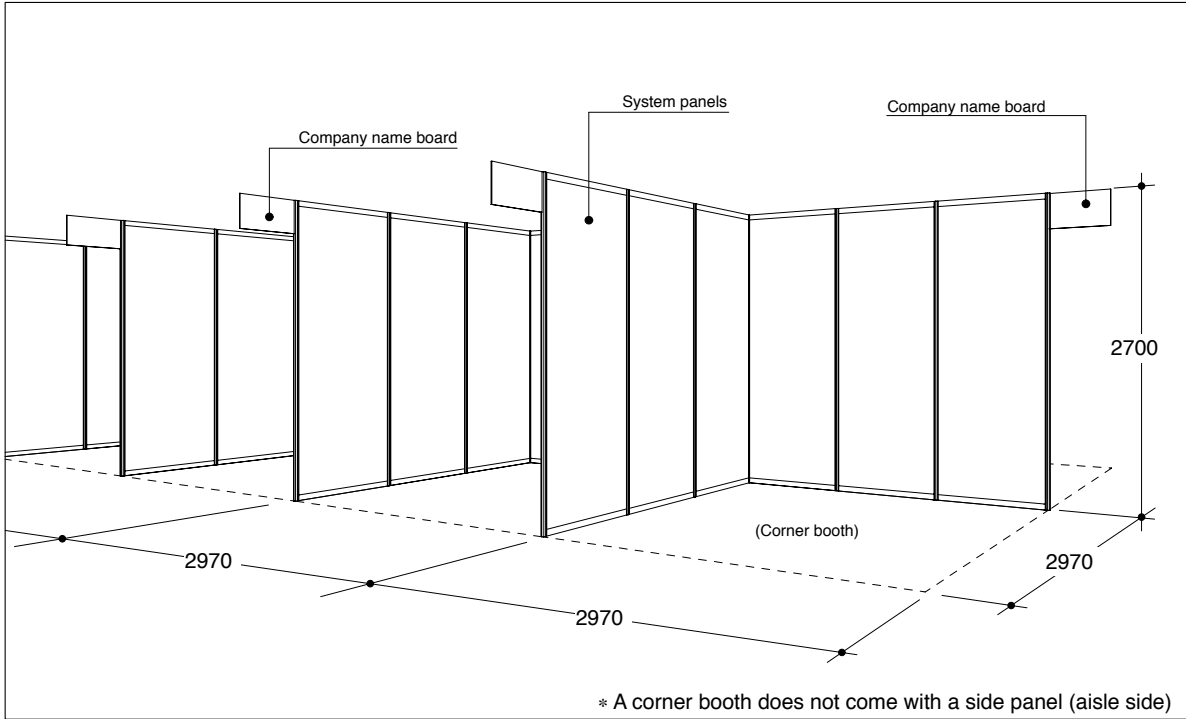

### ● Top View of Basic Booth

\*Measurements are from a center to a center of pillars.  
\*Unit : millimeters

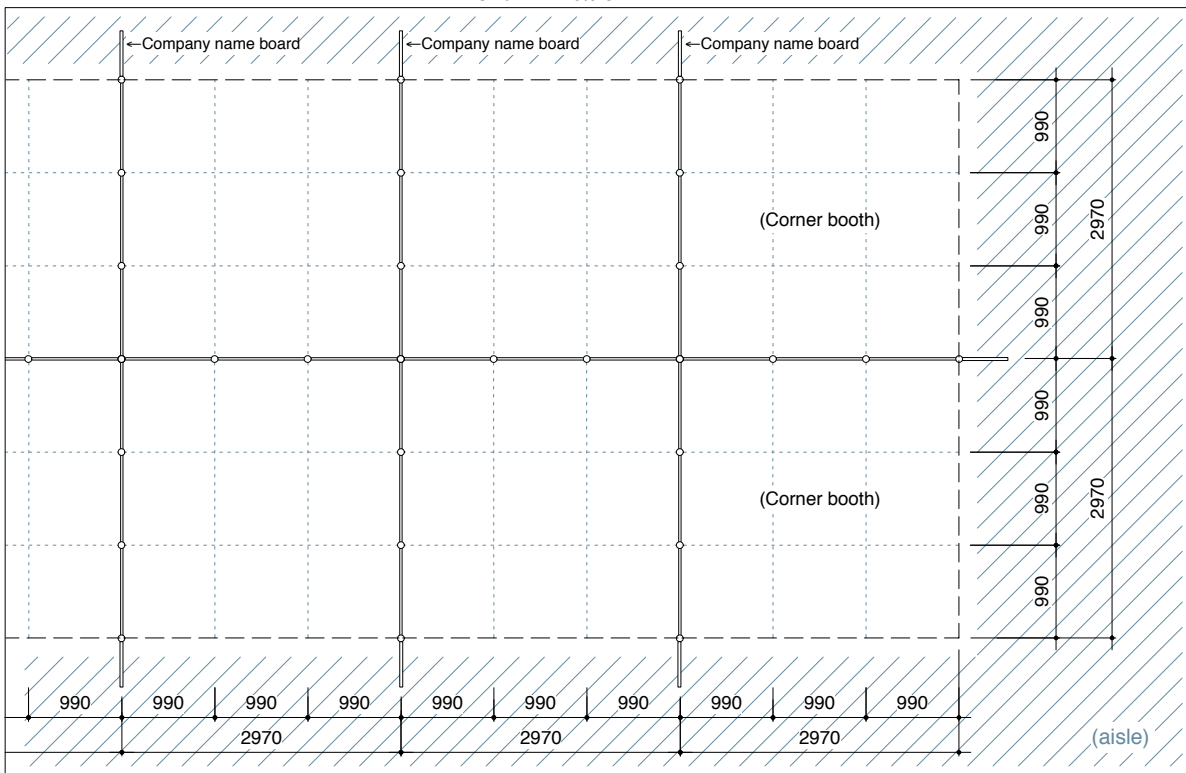

## ● The details of system panels

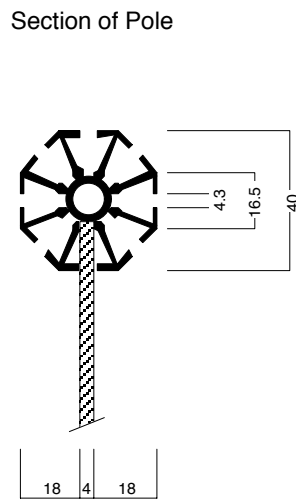
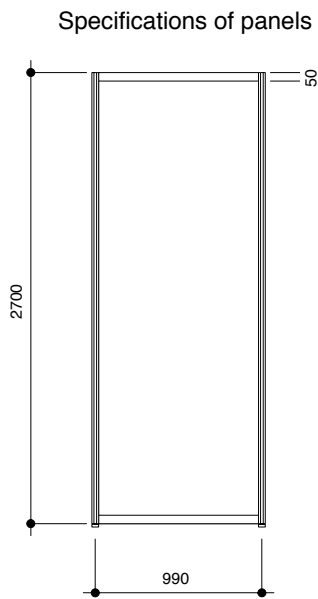

Specification of pole, beam, joint

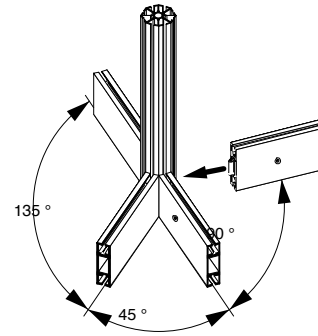

## ● Specification and notes

\*1 System panels are composed of vinyl-coated plywood with white color.

\*2 System panels cannot be directly decorated and processed.

- To cut, nail, or make holes on the system panel components(panel boards,poles,beams,etc.) is strictly prohibited.
- Neither pins nor a strong double-sided adhesive tape can be used.  
(If you use cellophane tape on a wall, please be sure to remove it.)

\*3 Panels can be mounted with S-shaped hooks with chain and /or a Velcro tape.

## Packaged Booth Information

In order to exhibit merchandises in simplified and cost-saving manners, we are recommending the use of the “Packaged Booth”

We provide a wide range of “Packaged Booths”: A basic “Packaged Booth” comes with basic items, and a high-class “Packaged Booth” comes with various items that meet your demand.

Furthermore, we can provide various optional tools to meet your original plans.

Exhibitors wishing to order this “Packaged Booth Display Order Form” and “Optional Tool Order Form” are requested to fill out the application form at the back of this manual and submit the form to Ten Co., Ltd. by June 28 (Fri.), 2019.

### Notes:

1) All indicated prices exclude tax and entry fee.

Electric trunk line construction costs and electric charge are charged separately.

(Please refer to “JASIS 2019 WEB” for information about electric construction fee and electricity charges. We will post the information on the site at the end of May.)

2) Exhibitors using cabinet, a key for exclusive use is available at exhibitors' request. (Pay) ¥700/ea

## ● Schedule

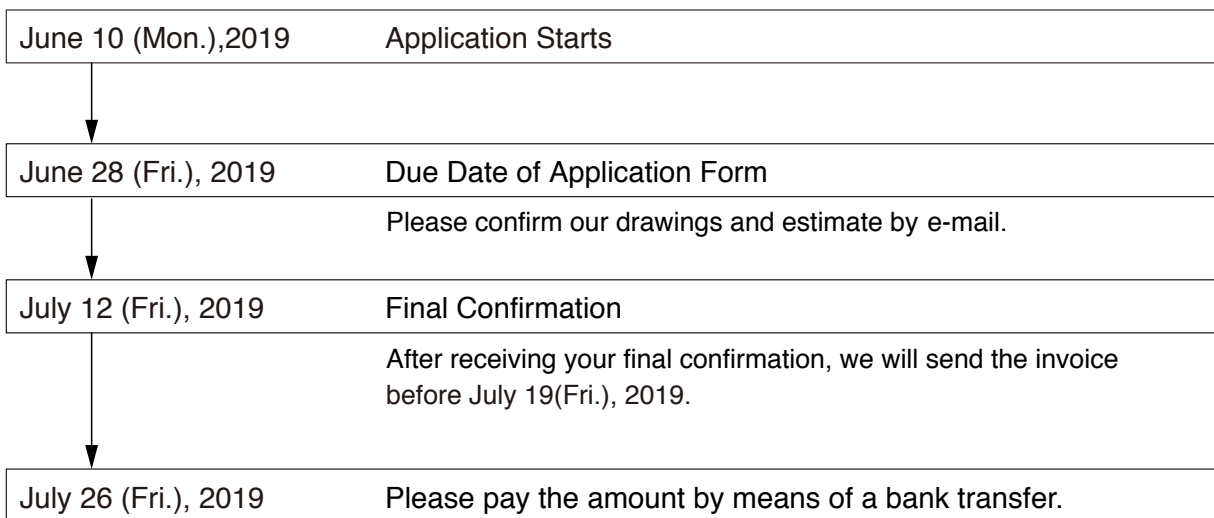

( The order for the construction of the booth will be placed when the full payment of the invoice has been made. We retain the right to reject the order if you fail to pay the invoice in full by the due date. Notwithstanding the above, we may accept such order at our option even if the full payment is delayed. In case of the acceptance of the order, the work schedule may be changed, if necessary, by discussion between the parties. )

For further information and request on “System Panel” and “Package Booth”, please contact the following company.

### **Ten Co.,LTD.**

Morimitu Shinkou Bldg.9F, 5-9, Kotobuki, 1-chome, Taitou-ku, Tokyo 111-0042, JAPAN

Fax : +81-3-3842-7720

E-mail : [jasis@teninc.co.jp](mailto:jasis@teninc.co.jp)

**★ I apologize for bothering you, but please contact us by e-mail.**

● Packaged Booth Display • 1 booth

Packaged Booth Display 1-A

Total ¥ 38,500 (8% tax and entry fee excluded)

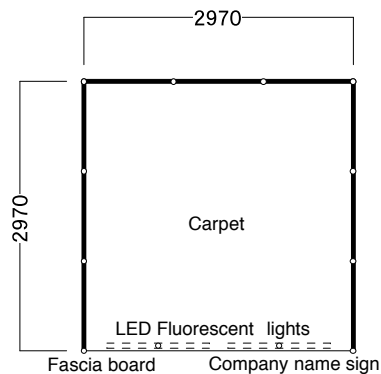
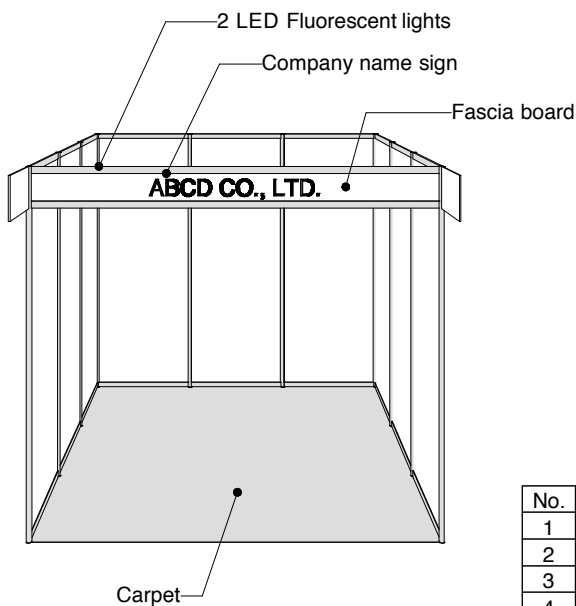

No.	Item	Notes	Q'ty
1	Fascia board		1
2	Company name sign	Font / Gothic Corner, Color / Black	1
3	LED Fluorescent lights	21W	2
4	Carpet	* Please refer to the color sample.	1

\* A corner booth comes with a header instead of side panel (aisle side).

Packaged Booth Display 1-B

Total ¥ 76,980 (8% tax and entry fee excluded)

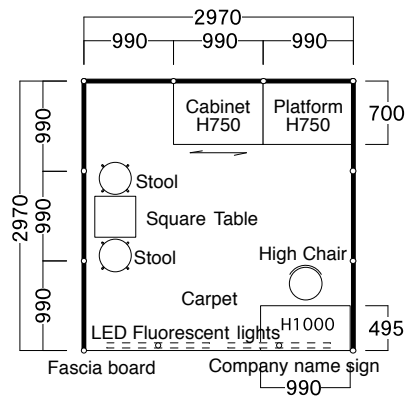
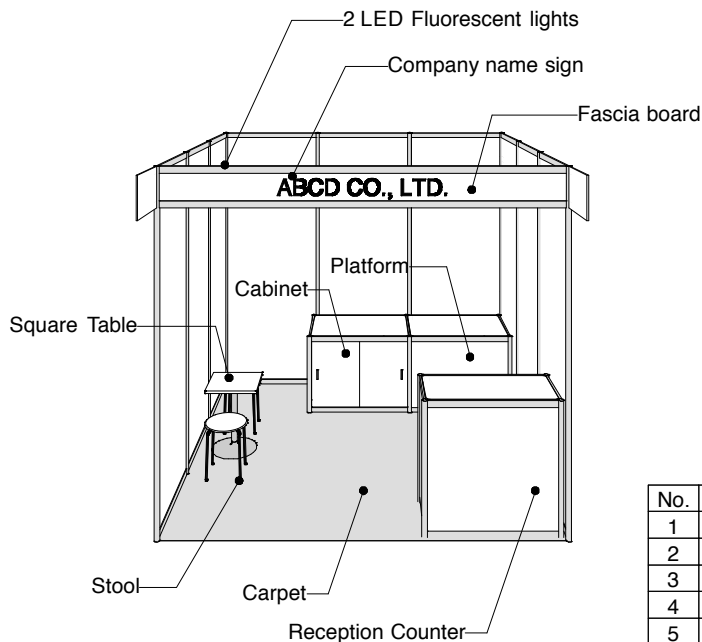

No.	Item	Notes	Q'ty
1	Fascia board		1
2	Company name sign	Font / Gothic Corner, Color / Black	1
3	LED Fluorescent lights	21W	2
4	Carpet	* Please refer to the color sample.	1
5	Platform	990*700*H750	1
6	Cabinet	990*700*H750	1
7	Reception Counter	990*495*H1000/ Ledge	1
8	High Chair		1
9	Square Table	450*450*H650	1
10	Stool		2

\* A corner booth comes with a header instead of side panel (aisle side).

\* The exclusive key for your cabinet is available at exhibitors' request.  
(Pay) ¥700/ea

# ● Packaged Booth Display • 1 booth

## Packaged Booth Display 1-C

Total ¥ 78,900 (8% tax and entry fee excluded)

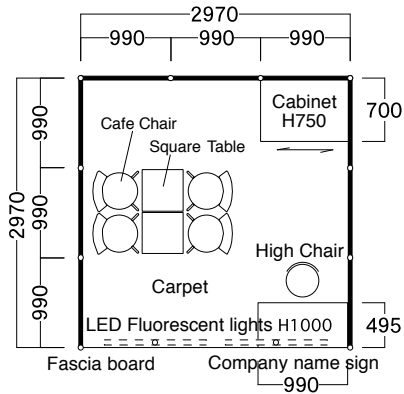
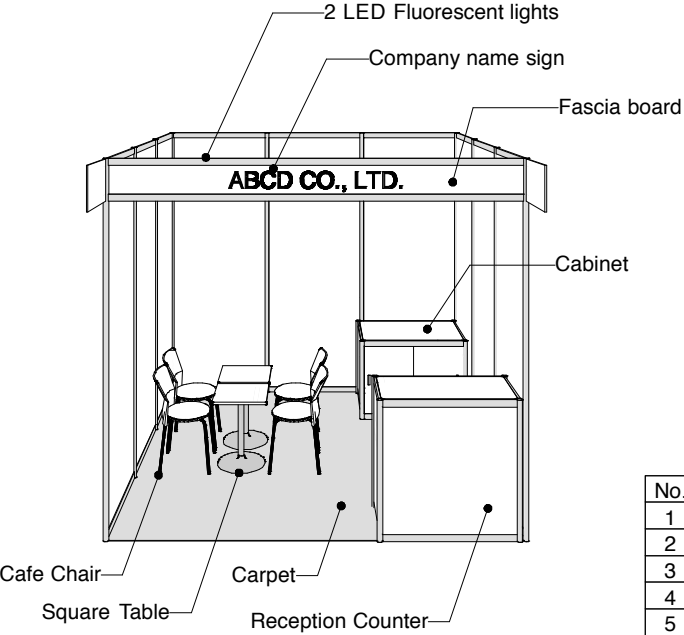

\* A corner booth comes with a header instead of side panel (aisle side).  
 \* The exclusive key for your cabinet is available at exhibitors' request.  
 (Pay) ¥700/ea

No.	Item	Notes	Q'ty
1	Fascia board		1
2	Company name sign	Font / Gothic Corner, Color / Black	1
3	LED Fluorescent lights	21W	2
4	Carpet	* Please refer to the color sample.	1
5	Cabinet	990*700*H750	1
6	Reception Counter	990*495*H1000/ Ledged	1
7	High Chair		1
8	Square Table	450*450*H650	2
9	Cafe Chair		4

## Packaged Booth Display 1-D

Total ¥ 83,700 (8% tax and entry fee excluded)

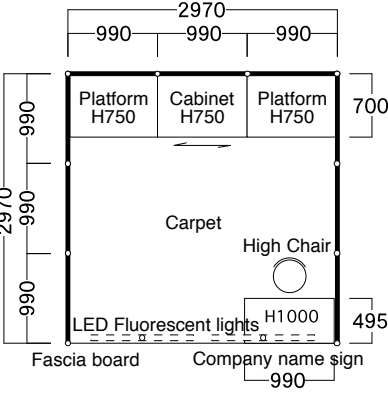
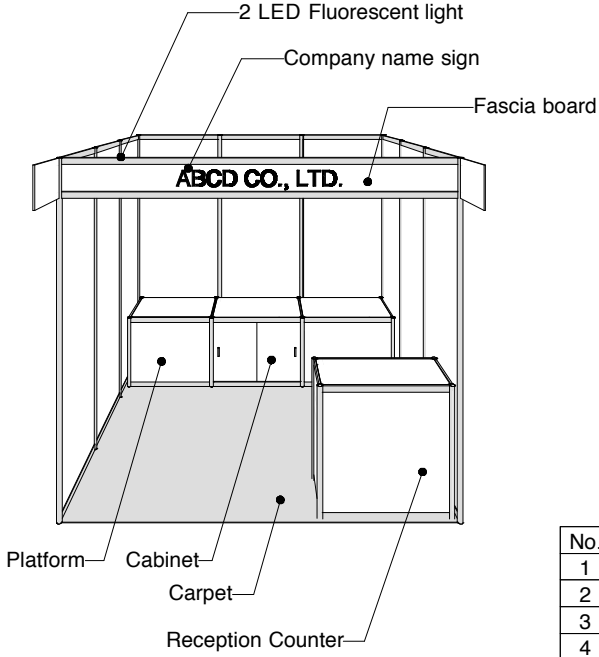

\* A corner booth comes with a header instead of side panel (aisle side).  
 \* The exclusive key for your cabinet is available at exhibitors' request.  
 (Pay) ¥700/ea

No.	Item	Notes	Q'ty
1	Fascia board		1
2	Company name sign	Font / Gothic Corner, Color / Black	1
3	LED Fluorescent lights	21W	2
4	Carpet	* Please refer to the color sample.	1
5	Platform	990*700*H750	2
6	Cabinet	990*700*H750	1
7	Reception Counter	990*495*H1000/ Ledged	1
8	High Chair		1

## ● Packaged Booth Display • 2 booths

### Packaged Booth Display 2-A

Total ¥ 77,000 (8% tax and entry fee excluded)

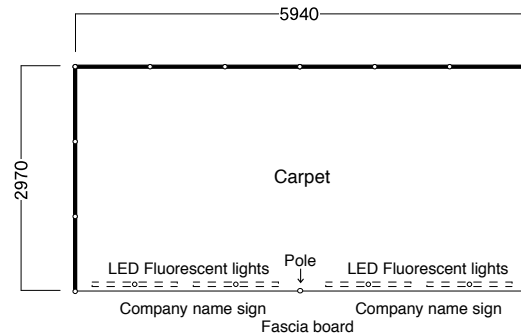
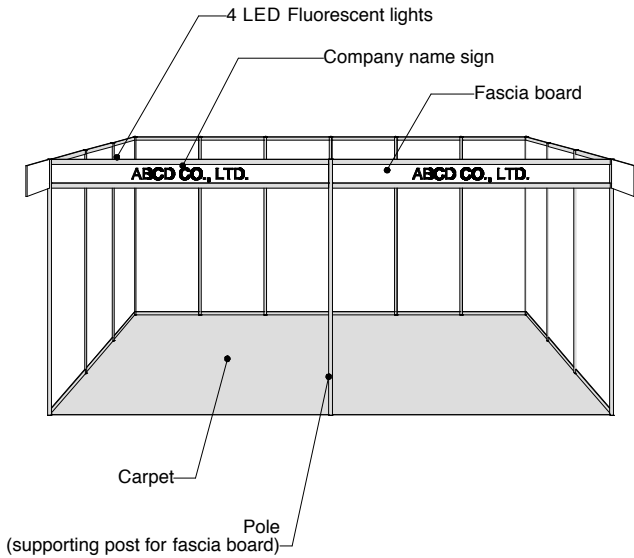

No.	Item	Notes	Q'ty
1	Fascia board		1
2	Pole	supporting post for fascia board	1
3	Company name sign	Font / Gothic Corner, Color / Black	2
4	LED Fluorescent lights	21W	4
5	Carpet	* Please refer to the color sample.	2

※ A corner booth comes with a header instead of side panel (aisle side).

### Packaged Booth Display 2-B

Total ¥ 164,400 (8% tax and entry fee excluded)

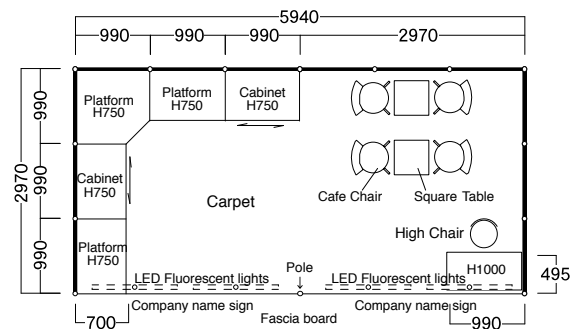
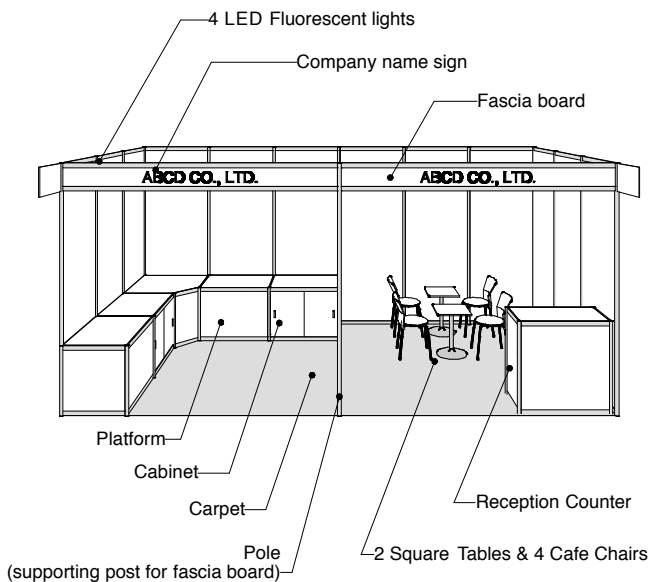

No.	Item	Notes	Q'ty
1	Fascia board		1
2	Pole	supporting post for fascia board	1
3	Company name sign	Font / Gothic Corner, Color / Black	2
4	LED Fluorescent lights	21W	4
5	Carpet	* Please refer to the color sample.	2
6	Platform	990*700*H750/2, 990*990*H750/1	3
7	Cabinet	990*700*H750	2
8	Reception Counter	990*495*H1000/ Ledged	1
9	High Chair		1
10	Square Table	450*450*H650	2
11	Cafe Chair		4

※ A corner booth comes with a header instead of side panel (aisle side).

※ The exclusive key for your cabinet is available at exhibitors' request.  
(Pay) ¥700/ea

## ● Packaged Booth Display • 2 booths

### Packaged Booth Display 2-C

Total ¥ 183,200 (8% tax and entry fee excluded)

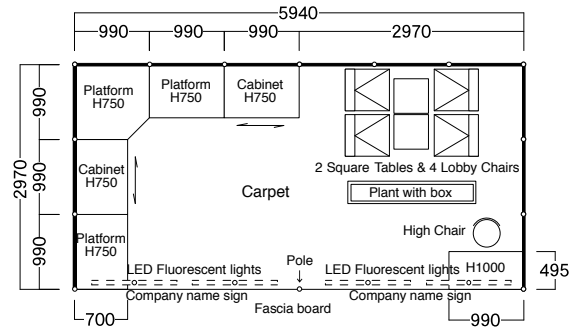
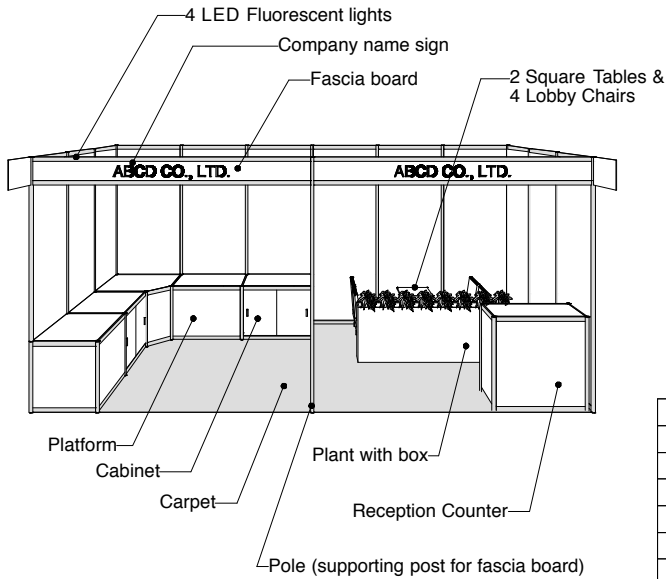

- \* A corner booth comes with a header instead of side panel (aisle side).
- \* The exclusive key for your cabinet is available at exhibitors' request.  
(Pay) ¥700/ea

No.	Item	Notes	Q'ty
1	Fascia board		1
2	Pole	supporting post for fascia board	1
3	Company name sign	Font / Gothic Corner, Color / Black	2
4	LED Fluorescent lights	21W	4
5	Carpet	* Please refer to the color sample.	2
6	Platform	990*700*H750/2, 990*990*H750/1	3
7	Cabinet	990*700*H750	2
8	Reception Counter	990*495*H1000/ Ledge	1
9	High Chair		1
10	Square Table	450*450*H650	2
11	Lobby Chair		4
12	Plant with box	W1800	1

### Packaged Booth Display 2-D

Total ¥ 184,480 (8% tax and entry fee excluded)

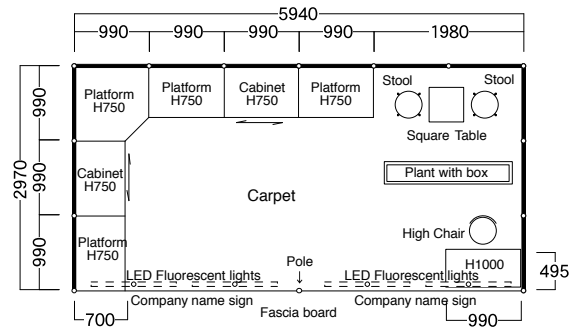
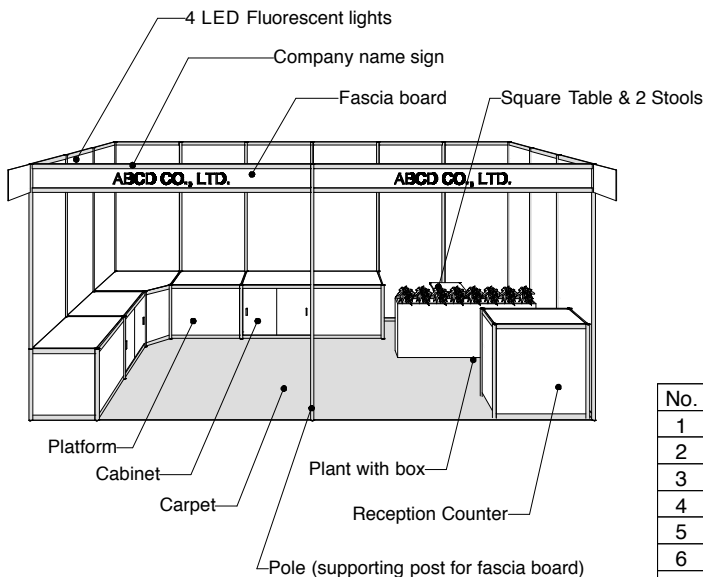

- \* A corner booth comes with a header instead of side panel (aisle side).
- \* The exclusive key for your cabinet is available at exhibitors' request.  
(Pay) ¥700/ea

No.	Item	Notes	Q'ty
1	Fascia board		1
2	Pole	supporting post for fascia board	1
3	Company name sign	Font / Gothic Corner, Color / Black	2
4	LED Fluorescent lights	21W	4
5	Carpet	* Please refer to the color sample.	2
6	Platform	990*700*H750/3, 990*990*H750/1	4
7	Cabinet	990*700*H750	2
8	Reception Counter	990*495*H1000/ Ledge	1
9	High Chair		1
10	Square Table	450*450*H650	1
11	Stool		2
12	Plant with box	W1800	1



## ● Packaged Booth Display • 3 booths

### Packaged Booth Display 3-A

Total ¥ 115,500 (8% tax and entry fee excluded)

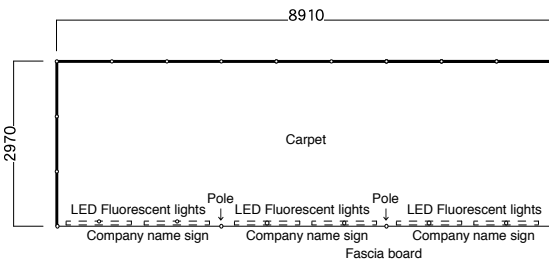
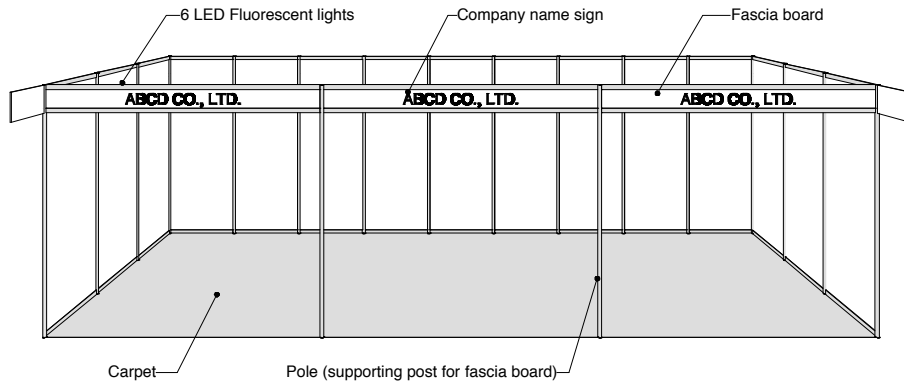

No.	Item	Notes	Q'ty
1	Fascia board		1
2	Pole	supporting post for fascia board	2
3	Company name sign	Font / Gothic Corner, Color / Black	3
4	LED Fluorescent lights	21W	6
5	Carpet	* Please refer to the color sample.	3

\* A corner booth comes with a header instead of side panel (aisle side).

### Packaged Booth Display 3-B

Total ¥ 257,400 (8% tax and entry fee excluded)

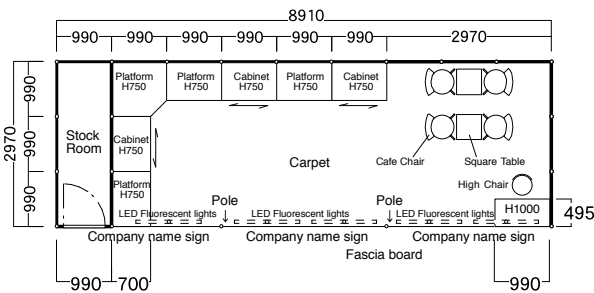
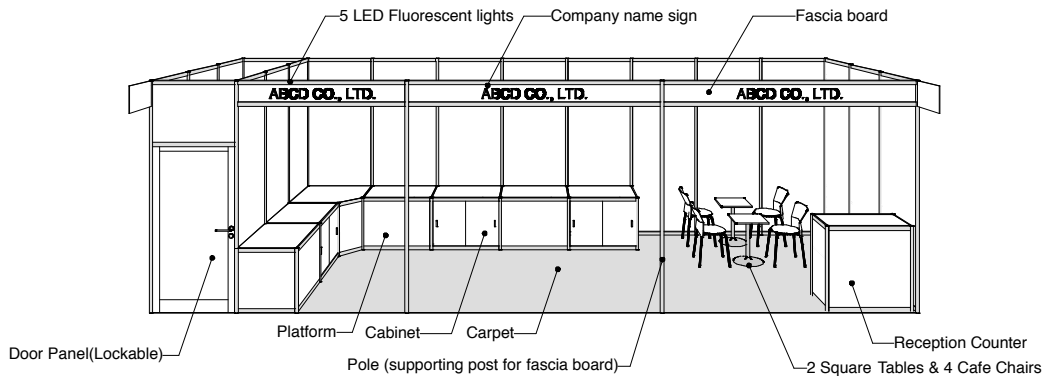

No.	Item	Notes	Q'ty
1	Fascia board		1
2	Pole	supporting post for fascia board	2
3	Company name sign	Font / Gothic Corner, Color / Black	3
4	LED Fluorescent lights	21W	5
5	Carpet	* Please refer to the color sample.	3
6	W990 Panel	H2700/Wall of Stock Room	3
7	Door Panel	W990*H2700 / Lockable	1
8	Platform	990*700*H750/3, 990*990*H750/1	4
9	Cabinet	990*700*H750	3
10	Reception Counter	990*495*H1000/ Ledged	1
11	High Chair		1
12	Square Table	450*450*H650	2
13	Cafe Chair		4

\* A corner booth comes with a header instead of side panel (aisle side).

\* The exclusive key for your cabinet is available at exhibitors' request.  
(Pay) ¥700/ea

# ● Packaged Booth Display • 3 booths

## Packaged Booth Display 3-C

Total ¥ 262,260 (8% tax and entry fee excluded)

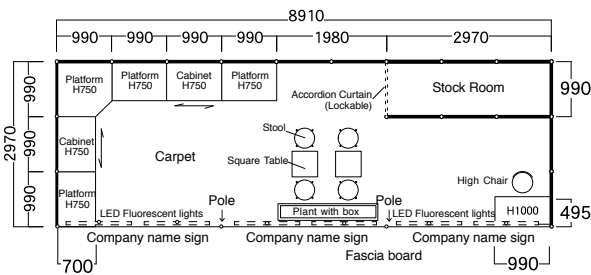
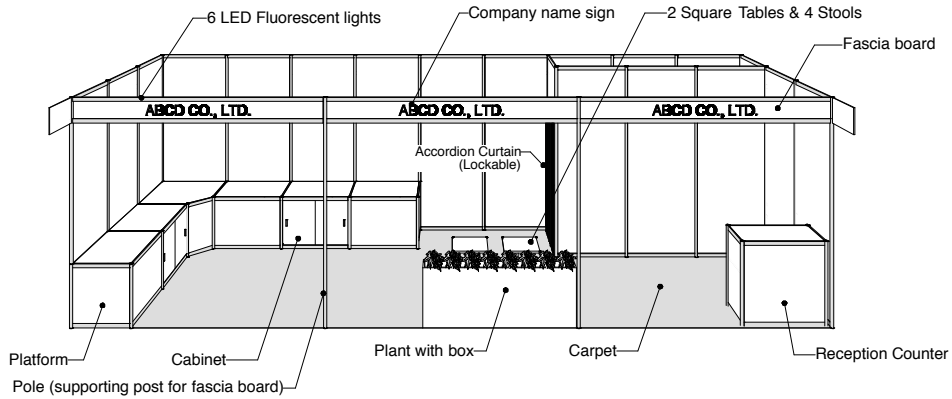

No.	Item	Notes	Q'ty
1	Fascia board		1
2	Pole	supporting post for fascia board	2
3	Company name sign	Font / Gothic Corner, Color / Black	3
4	LED Fluorescent lights	21W	6
5	Carpet	* Please refer to the color sample.	3
6	W990 Panel	H2700/Wall of Stock Room	3
7	Accordion Curtain	W990*H2700 / Lockable	1
8	Platform	990*700*H750/3, 990*990*H750/1	4
9	Cabinet	990*700*H750	2
10	Reception Counter	990*495*H1000/ Ledged	1
11	High Chair		1
12	Square Table	450*450*H650	2
13	Stool		4
14	Plant with box	W1800	1

- \* A corner booth comes with a header instead of side panel (aisle side).
- \* The exclusive key for your cabinet is available at exhibitors' request.  
(Pay) ¥700/ea

## Packaged Booth Display 3-D

Total ¥ 276,200 (8% tax and entry fee excluded)

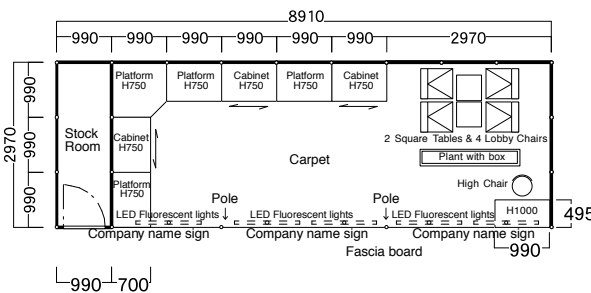
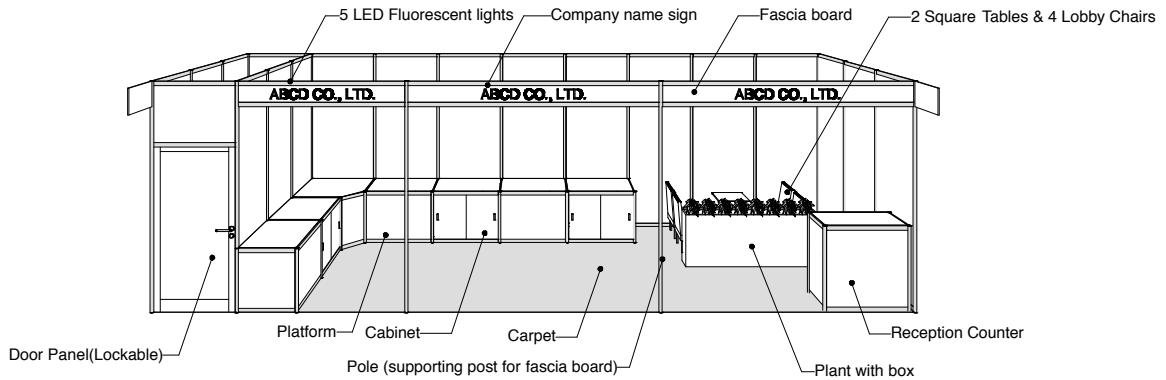

No.	Item	Notes	Q'ty
1	Fascia board		1
2	Pole	supporting post for fascia board	2
3	Company name sign	Font / Gothic Corner, Color / Black	3
4	LED Fluorescent lights	21W	5
5	Carpet	* Please refer to the color sample.	3
6	W990 Panel	H2700/Wall of Stock Room	3
7	Door Panel	W990*H2700 / Lockable	1
8	Platform	990*700*H750/3, 990*990*H750/1	4
9	Cabinet	990*700*H750	3
10	Reception Counter	990*495*H1000/ Ledged	1
11	High Chair		1
12	Square Table	450*450*H650	2
13	Lobby Chair		4
14	Plant with box	W1800	1

- \* A corner booth comes with a header instead of side panel (aisle side).
- \* The exclusive key for your cabinet is available at exhibitors' request.  
(Pay) ¥700/ea

## ● Optional Tool ●

Option Tool 1-16

System parts

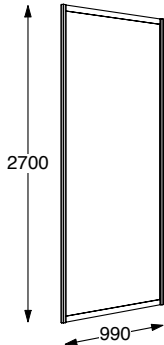
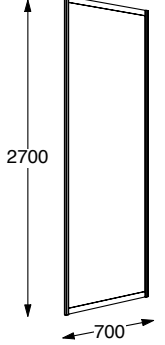
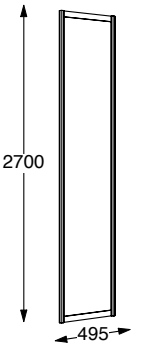
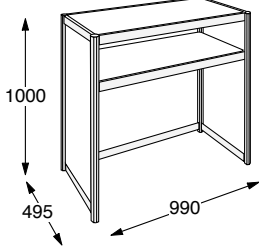
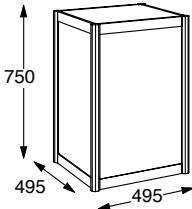
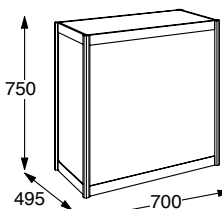
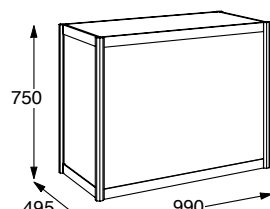
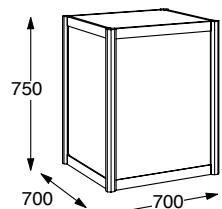
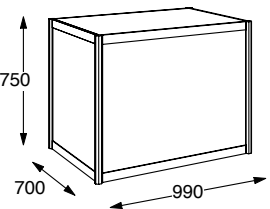
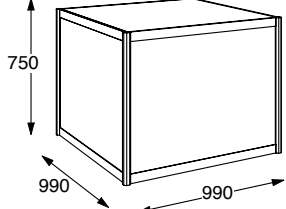
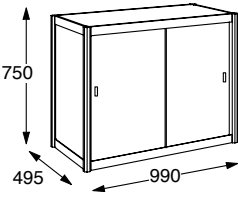
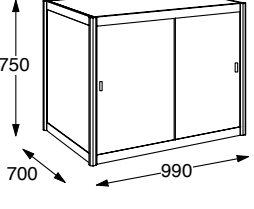
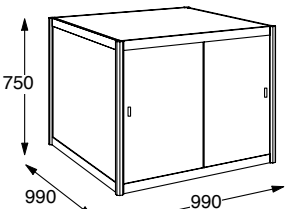
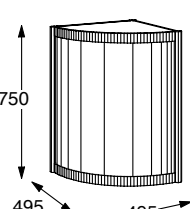
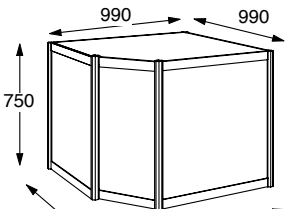
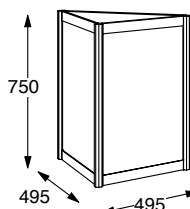
 <p>2700 990</p>	 <p>2700 700</p>	 <p>2700 495</p>	 <p>1000 495 990</p> <p>W990×D495×H1000</p>
<p><b>1</b> Wall Panel (W990) ¥6,000</p>	<p><b>2</b> Wall Panel (W700) ¥5,000</p>	<p><b>3</b> Wall Panel (W495) ¥5,000</p>	<p><b>4</b> Reception Counter ¥10,000</p>
<p>Withstand Load: 60kg</p>  <p>750 495 495</p> <p>W495×D495×H750</p>	<p>Withstand Load: 60kg</p>  <p>750 495 700</p> <p>W700×D495×H750</p>	<p>Withstand Load: 60kg</p>  <p>750 495 990</p> <p>W990×D495×H750</p>	<p>Withstand Load: 60kg</p>  <p>750 700 700</p> <p>W700×D700×H750</p>
<p><b>5</b> Display Platform ¥5,000</p>	<p><b>6</b> Display Platform ¥6,000</p>	<p><b>7</b> Display Platform ¥7,000</p>	<p><b>8</b> Display Platform ¥8,000</p>
<p>Withstand Load: 60kg</p>  <p>750 700 990</p> <p>W990×D700×H750</p>	<p>Withstand Load: 60kg</p>  <p>750 990 990</p> <p>W990×D990×H750</p>	<p>Withstand Load: 60kg</p>  <p>750 495 990</p> <p>W990×D495×H750</p>	<p>Withstand Load: 60kg</p>  <p>750 700 990</p> <p>W990×D700×H750</p>
<p><b>9</b> Display Platform ¥10,000</p>	<p><b>10</b> Display Platform ¥13,000</p>	<p><b>11</b> Cabinet ¥9,000</p>	<p><b>12</b> Cabinet ¥12,000</p>
<p>Withstand Load: 60kg</p>  <p>750 990 990</p> <p>W990×D990×H750</p>	<p>Withstand Load: 60kg</p>  <p>750 495 495</p> <p>W495×D495×H750</p>	<p>Withstand Load: 60kg</p>  <p>990 990 750 700 700</p> <p>W990×D990×H750</p>	<p>Withstand Load: 60kg</p>  <p>750 495 495</p> <p>W495×D495×H750</p>
<p><b>13</b> Cabinet ¥15,000</p>	<p><b>14</b> 495R Display Platform ¥7,000</p>	<p><b>15</b> Corner Display Platform ¥15,000</p>	<p><b>16</b> 495L Display Platform ¥5,000</p>

\* The exclusive key for your cabinet is available at exhibitors' request. (Pay) ¥700/ea

● Optional Tool ●











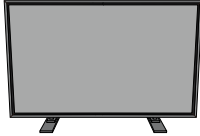

Option Tool 17-32

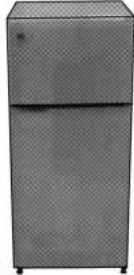
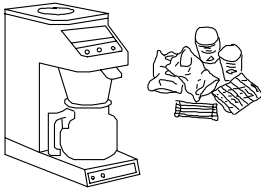
System parts/etc.

 <p>2700 990 Lockable</p>	 <p>2700 990</p>	 <p>2700 990 Lockable</p>	 <p>300 990</p>
<p><b>17</b> Accordion Curtain ¥18,000</p>	<p><b>18</b> Acrylic Panel ¥20,000</p>	<p><b>19</b> Door Panel ¥20,000</p>	<p><b>20</b> Shelf Board ¥3,500</p>
 <p>300</p>		 <p>900 900 Hooks (No. 22) included</p>	 <p>W1200×D600×H940</p>
<p><b>21</b> Fascia Board ¥2,500/m</p>	<p><b>22</b> Hooks for Mesh Panel ( 4 ) ¥1,000</p>	<p><b>23</b> Mesh panel ¥6,000</p>	<p><b>24</b> Counter unit (with shelves inside) ¥10,000</p>
 <p>(A4-size, 12 racks)</p>	 <p>(A4-size, 3 racks)</p>		 <p>W1800×D600×H730</p>
<p><b>25</b> Catalogue Rack ¥5,600</p>	<p><b>26</b> Desk-top Catalogue Rack ¥1,600</p>	<p><b>27</b> Fire Extinguisher ¥4,000</p>	<p><b>28</b> Table ¥3,200</p>
 <p>W600×D600×H650</p>	 <p>Ø750×H650</p>		
<p><b>29</b> Square Table ¥2,000</p>	<p><b>30</b> Round Table ¥4,000</p>	<p><b>31</b> Folding Chair ¥640</p>	<p><b>32</b> Stacking Chair ¥3,200</p>

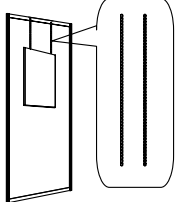

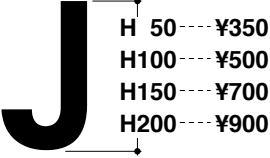
● Optional Tool ●

Option Tool 33-48 Rental

 <p><b>33</b> High Chair ¥3,200</p>	 <p><b>34</b> Reception Room Furniture Set ¥10,000</p>	 <p><b>35</b> Name Card Box ¥1,600</p>	 <p>The Self-standing tabletop (Video and Personal computer support) Body (1920×1080 pixels) equipped with speaker. Body size : W973×H566×D126 / ≈22kg Body size with stands : W973×H602×D270 / ≈24kg * The cost includes the rental fee for 3 days, the transportation fee, and the adjustment fee. * There is the case that the specifications may be different from the original because of the lack of the stocks. * There will be the additional charge for installation to wall. Please apply for 100V outlet (225W) separately.</p> <p><b>36</b> 42" Wide-LCD ¥81,000</p>																																				
 <p>W900×D450×H1800</p> <p><b>37</b> Steel shelf ¥6,000</p>	 <p>(Middle size: 100 lit.) Please apply for 100V outlet (100W) separately.</p> <p><b>38</b> Refrigerator ¥16,000</p>	 <p>The coffee maker and the coffee beans, sugar, creams, paper cups, and stirrers for 100 people Please apply for 100V outlet (1.5kW) separately.</p> <p><b>39</b> The Coffee Maker &amp; The Coffee Set ¥23,600</p>	 <p><b>40</b> Planter(Large) ¥3,500</p>																																				
 <p><b>41</b> Planter(Small) ¥1,000</p>	 <p>W1800 ¥22,000 W1300 ¥16,000 W 900 ¥11,000</p> <p><b>42</b> Flower box</p>	<table border="1"> <tbody> <tr><td>Red</td><td>No.P-1</td></tr> <tr><td>Dark blue</td><td>No.P-2</td></tr> <tr><td>Green</td><td>No.P-3</td></tr> <tr><td>Dark gray</td><td>No.P-4</td></tr> <tr><td>Orange</td><td>No.P-5</td></tr> <tr><td>Blue</td><td>No.P-6</td></tr> <tr><td>Light gray</td><td>No.P-7</td></tr> <tr><td>Yellowish green</td><td>No.P-8</td></tr> </tbody> </table> <p>* Please refer to the color sample.</p> <p><b>43</b> Carpet (Needle punched carpet) ¥2,000/m<sup>2</sup></p>	Red	No.P-1	Dark blue	No.P-2	Green	No.P-3	Dark gray	No.P-4	Orange	No.P-5	Blue	No.P-6	Light gray	No.P-7	Yellowish green	No.P-8	<table border="1"> <tbody> <tr><td>■ Monotint</td><td>Cream No.1</td></tr> <tr><td></td><td>Yellow No.2</td></tr> <tr><td></td><td>Pink No.3</td></tr> <tr><td></td><td>Red No.4</td></tr> <tr><td></td><td>Light blue No.5</td></tr> <tr><td></td><td>Blue No.6</td></tr> <tr><td></td><td>Mint green No.7</td></tr> <tr><td></td><td>Green No.8</td></tr> <tr><td></td><td>Black No.9</td></tr> <tr><td>■ Pattern</td><td>Grain pattern No.10</td></tr> </tbody> </table> <p>¥5,500/span ¥7,200/span</p> <p>* 1span=W990×H2700 * Please refer to the color sample.</p> <p><b>44</b> Coloring for Wall</p>	■ Monotint	Cream No.1		Yellow No.2		Pink No.3		Red No.4		Light blue No.5		Blue No.6		Mint green No.7		Green No.8		Black No.9	■ Pattern	Grain pattern No.10
Red	No.P-1																																						
Dark blue	No.P-2																																						
Green	No.P-3																																						
Dark gray	No.P-4																																						
Orange	No.P-5																																						
Blue	No.P-6																																						
Light gray	No.P-7																																						
Yellowish green	No.P-8																																						
■ Monotint	Cream No.1																																						
	Yellow No.2																																						
	Pink No.3																																						
	Red No.4																																						
	Light blue No.5																																						
	Blue No.6																																						
	Mint green No.7																																						
	Green No.8																																						
	Black No.9																																						
■ Pattern	Grain pattern No.10																																						
<p>To hung up the explanation panel, graphic panel, and so on</p>  <p>For one panel One set has two s-shaped hooks with chain.</p>  <p>For one panel One set has four Velcro tapes of 3sq mm.</p> <p><b>45</b> S-shaped hooks with chain ¥600</p> <p><b>46</b> Velcro tape. ¥600</p>		 <p>H 50 ---- ¥350 H100 ---- ¥500 H150 ---- ¥700 H200 ---- ¥900</p> <p>* Black Letter (unified font) (When you have preferred color or logo, please contact us by e-mail.)</p> <p><b>47</b> Cutting Letters</p>	 <p>W900×H150</p> <p>* Styrene Board/Black Letter (unified font) (When you have preferred color or logo, please contact us by e-mail.)</p> <p><b>48</b> Company Name Plate ¥4,000</p>																																				

# ● Optional Tool ●

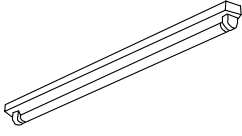
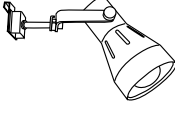
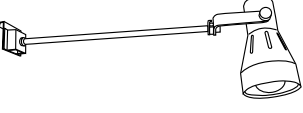
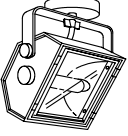
## Option Tool 49-54 Rental

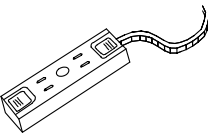
<p>* Wiring fee for trunk line and electricity charge are required separately.</p>  <p>(21W)</p>	<p>* Wiring fee for trunk line and electricity charge are required separately.</p>  <p>(11W)</p>	<p>* Wiring fee for trunk line and electricity charge are required separately.</p>  <p>(11W)</p>	<p>* Wiring fee for trunk line and electricity charge are required separately.</p>  <p>(300W)</p>								
<p><b>49</b> LED Fluorescent Light ¥3,000</p>	<p><b>50</b> LED Spot Light ¥3,000</p>	<p><b>51</b> LED Spot Light with Arm ¥3,500</p>	<p><b>52</b> Halogen Lamp ¥7,000</p>								
<p>* Wiring fee for trunk line and electricity charge are required separately.</p>  <p>(70W)</p>	<p>* Wiring fee for trunk line and electricity charge are required separately.</p>  <p>★ Please indicate the capacity. (Maximum is 1.5kW per an outlet.) <b>Please let us know if you would like 200V outlet</b></p>	<p>The following construction fee of the electric panel boards will be required if the total electrical capacity exceeds over 1500W. (The fluorescent lamps in the package booth are included.)</p> <table border="1"> <thead> <tr> <th>Total Capacity</th> <th>Fee for Distribution Panel</th> </tr> </thead> <tbody> <tr> <td>less than 1,500W</td> <td>not necessary</td> </tr> <tr> <td>over 1,501W under 3,000W</td> <td>¥6,000</td> </tr> <tr> <td>over 3,001W under 4,500W</td> <td>¥9,000</td> </tr> </tbody> </table> <p>★ Over 3000W, it is charged 3,000 yen every additional 1,500W</p>		Total Capacity	Fee for Distribution Panel	less than 1,500W	not necessary	over 1,501W under 3,000W	¥6,000	over 3,001W under 4,500W	¥9,000
Total Capacity	Fee for Distribution Panel										
less than 1,500W	not necessary										
over 1,501W under 3,000W	¥6,000										
over 3,001W under 4,500W	¥9,000										
<p><b>53</b> HID 70W ¥9,400</p>	<p><b>54</b> 100V Outlet ¥2,500</p>										

● Color Sample ●

System Panels

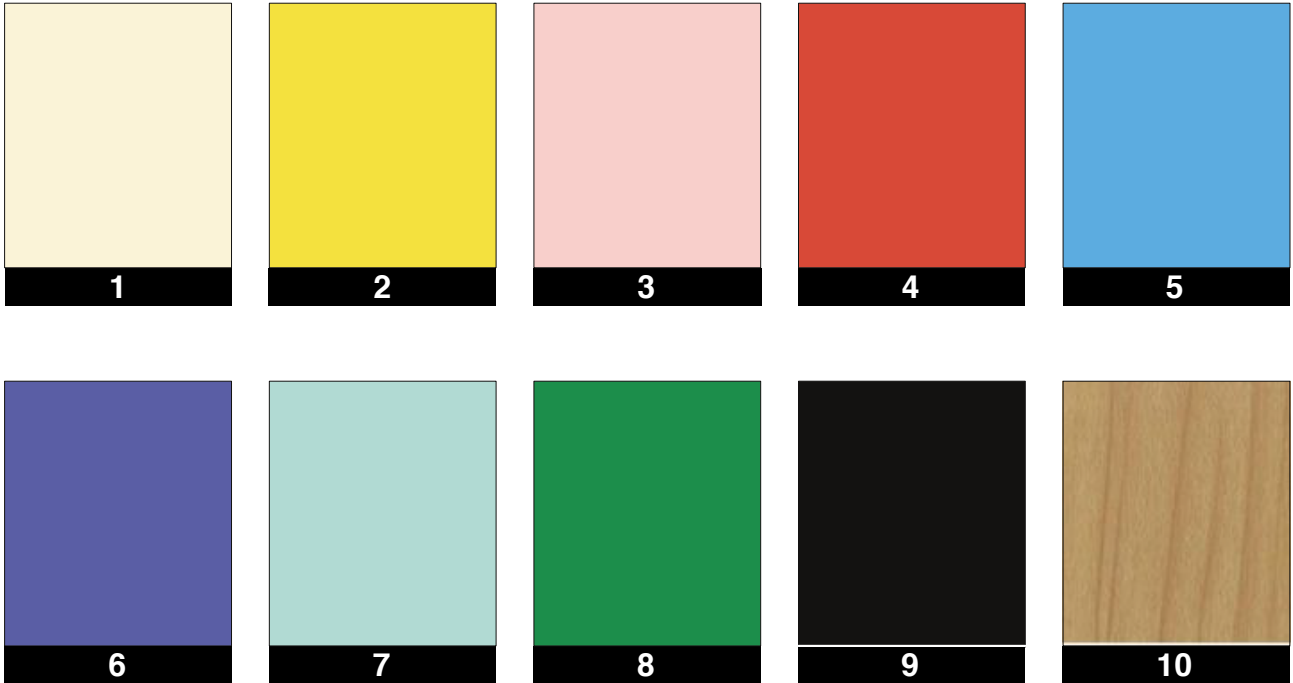

Carpet (Needle punched carpet)

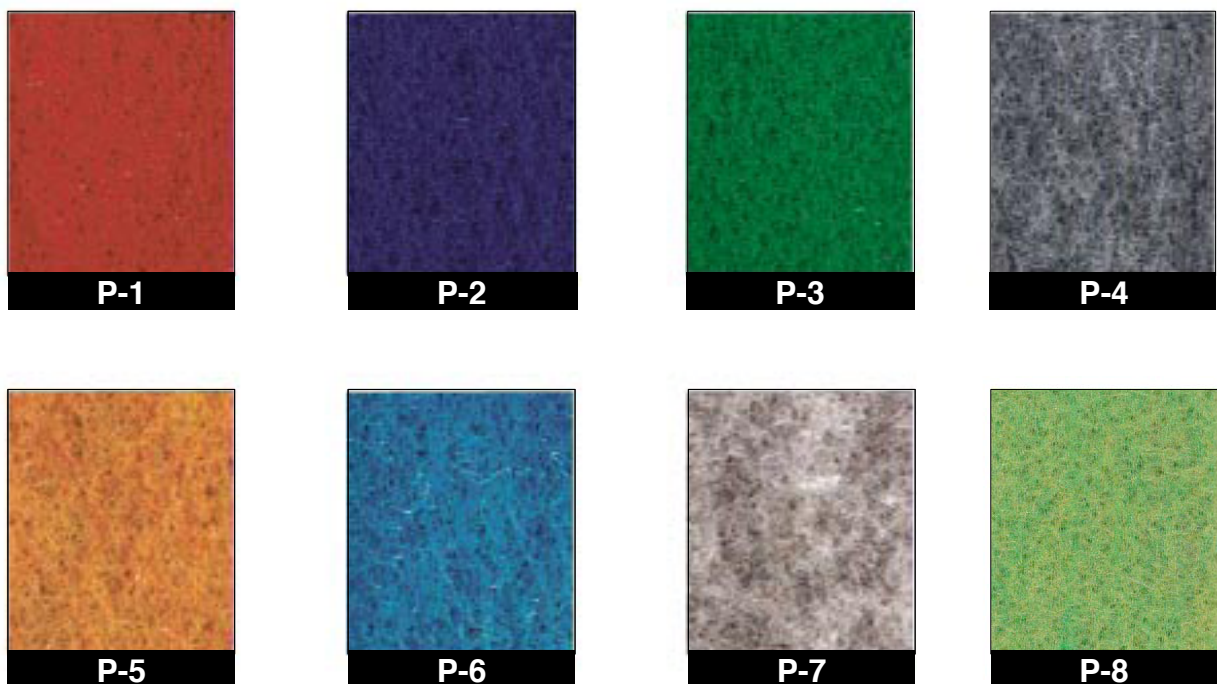

# Packaged Booth Display Order Form

[ Application Starts : June 10 (Mon.), 2019 ]

[ Due Date : June 28 (Fri.), 2019 ]



Application date : (Month) (Day), 2019

Booth No.			
Company Name			
Department		Person in Charge	
Adress	-----		
TEL		FAX	
E-mail			

◆ Circle the No. of the packaged booth which you would like to order.

No.	Packaged Booth Display	Price
1	Packaged Booth Display 1-A (1 booth)	¥38,500 ( 8% tax and entry fee excluded )
2	Packaged Booth Display 1-B (1 booth)	¥76,980 ( 8% tax and entry fee excluded )
3	Packaged Booth Display 1-C (1 booth)	¥78,900 ( 8% tax and entry fee excluded )
4	Packaged Booth Display 1-D (1 booth)	¥83,700 ( 8% tax and entry fee excluded )
5	Packaged Booth Display 2-A (2 booths)	¥77,000 ( 8% tax and entry fee excluded )
6	Packaged Booth Display 2-B (2 booths)	¥164,400 ( 8% tax and entry fee excluded )
7	Packaged Booth Display 2-C (2 booths)	¥183,200 ( 8% tax and entry fee excluded )
8	Packaged Booth Display 2-D (2 booths)	¥184,480 ( 8% tax and entry fee excluded )
9	Packaged Booth Display 3-A (3 booths)	¥115,500 ( 8% tax and entry fee excluded )
10	Packaged Booth Display 3-B (3 booths)	¥257,400 ( 8% tax and entry fee excluded )
11	Packaged Booth Display 3-C (3 booths)	¥262,260 ( 8% tax and entry fee excluded )
12	Packaged Booth Display 3-D (3 booths)	¥276,200 ( 8% tax and entry fee excluded )

◆ Selection of the color of the carpet 《Mandatory》

Circle the color No. of the carpet which you would like to order. \*Please refer to the color sample

No.	P-1	P-2	P-3	P-4	P-5	P-6	P-7	P-8
-----	-----	-----	-----	-----	-----	-----	-----	-----

◆ Put a check mark in the box below depending on necessity.

In addition to the above packaged booth, we would like to order optional tools.

(When you put a check mark in the above box, please fill in the attached "Optional Tool Order Form" )

Submit order form	<p><b>Ten Co.,LTD.</b>                  Adress : Morimitu Shinkou Bldg.9F,5-9, Kotobuki 1-chome, Taitou-ku, Tokyo 111-0042 Japan                  Fax : +81-3-3842-7720 E-mail : jasis@teninc.co.jp                  ★ I apologize for bothering you, but please contact us by e-mail</p>
-------------------	---



<b>Booth No.</b>	<b>Company Name</b>		
<b>Address</b>		<b>FAX</b>	
<b>Department</b>	<b>Person in Charge</b>	<b>E-mail</b>	
Submit order form	<b>Ten Co.,LTD.</b> Address : Morimitu Shinkou Bldg.9F,5-9, Kotobuki 1-chome, Taitou-ku, Tokyo 111-0042 Japan Fax : +81-3-3842-7720      E-mail : jasis@teninc.co.jp		

- When you submit the attached “Packaged Booth Display Order Form,” put a check mark in the box at right. →→→
- Please indicate preferable location of each item and the capacity and location of outlet when using the electrical power supply.

<div style="border: 1px dashed black; width: 100%; height: 100%;"></div>	<p style="text-align: center;">[ Layout Example ]</p>
--	---

● Option items

No.	Items	Q'ty	Price	Charge	Note	No.	Items	Q'ty	Price	Charge	Note
1	Wall Panel (W990×H2700)		6,000			32	Stacking Chair		3,200		
2	Wall Panel (W700×H2700)		5,000			33	High Chair		3,200		
3	Wall Panel (W495×H2700)		5,000			34	Reception room Furniture Set	Set	10,000		
4	Reception Counter (W990×D495×H1000)		10,000			35	Name Card Box		1,600		
5	Display Platform (W495×D495×H750)		5,000			36	42" Wide-LCD		81,000		
6	Display Platform (W700×D495×H750)		6,000			37	Steel shelf (W900×D450×H1800)		6,000		
7	Display Platform (W990×D495×H750)		7,000			38	Refrigerator (Middle size: 100 lit.)		16,000		
8	Display Platform (W700×D700×H750)		8,000			39	The Coffee Maker & The Coffee Set		23,600		
9	Display Platform (W990×D700×H750)		10,000			40	Planter (Large)		3,500		
10	Display Platform (W990×D990×H750)		13,000			41	Planter (Small)		1,000		
11	Cabinet (W990×D495×H750)		9,000			42	Flower box W1800		22,000		
12	Cabinet (W990×D700×H750)		12,000			42	Flower box W1300		16,000		
13	Cabinet (W990×D990×H750)		15,000			42	Flower box W900		11,000		
14	495R Display Platform (W495×D495×H750)		7,000			43	Carpet (Needle punched carpet)	m <sup>2</sup>	2,000		Color (No : )
15	Corner Display Platform (W990×D990×H750)		15,000			44	Coloring for Wall (Monotint)	span	5,500		Color (No : )
16	495L Display Platform (W495×D495×H750)		5,000			44	Coloring for Wall (Grain Pattern)	span	7,200		No .10
17	Accordion Curtain		18,000			45	S-shaped hooks with chain		600		
18	Acrylic Panel		20,000			46	Velcro tape		600		
19	Door Panel (Lockable)		20,000			47	Cutting Letters H50	letter	350		
20	Shelf Board (W990×D300)		3,500			47	Cutting Letters H100	letter	500		
21	Fascia Board	m	2,500			47	Cutting Letters H150	letter	700		
22	Hooks for Mesh Panel ( 4 )	Set	1,000			47	Cutting Letters H200	letter	900		
23	Mesh panel (W900×H900)		6,000		Hooks (No. 22) included	48	Company Name Plate (W900×H150)		4,000		
24	Counter unit (W1200×D600×H940)		10,000		(with shelves inside)	49	LED Fluorescent Light (21W)		3,000		
25	Catalogue Rack (A4-size, 12 racks)		5,600			50	LED Spot Light (11W)		3,000		
26	Desk-top Catalogue Rack (A4-size, 3 racks)		1,600			51	LED Spot Light with Arm (11W)		3,500		
27	Fire Extinguisher		4,000			52	Halogen Lamp (300W)		7,000		
28	Table (W1800×D600×H730)		3,200			53	HID (70W)		9,400		
29	Square Table (W600×D600×H650)		2,000			54	100V Outlet		2,500		electric capacity ( W)
30	Round Table (Ø750×H650)		4,000								
31	Folding Chair		640								
<b>Total</b>											

\* All indicated prices exclude tax and entry fee. And the show management will send a bill for the trunk line construction fee and electric charge separately.