



---

## Specifications of basic booths ( System panels booth )

- Specifications of basic booths (P1)
- Top View of Basic Booth (P1)
- Specifications of basic booth components (P2)
- Notes (P2)

---

## Packaged Booth Information

- Schedule (P3)
- Packaged Booth Display • 1 booth (P4, P5)
- Packaged Booth Display • 2 booths (P6, P7)
- Packaged Booth Display • 3 booths (P8, P9)

---

## Optional Tools (P10- P13)

---

## Color Sample (P14)

---

## Order Form

- Packaged Booth Display Order Form (P15)
- Optional Tool Order Form (P16)

For further information and request on "System Panel" and "Package Booth",  
please contact the following company.

### **Ten Co.,LTD.**

Morimitu Shinkou Bldg.9F, 5-9, Kotobuki, 1-chome, Taitou-ku, Tokyo 111-0042, JAPAN

Fax : +81-3-3842-7720

E-mail : jasis@teninc.co.jp

★ I apologize for bothering you, but please contact us by E-mail.

## Specifications of basic booths ( System panels booth )

The specifications of system panels which we use for basic booths are as follows.

### ● Specifications of basic booths

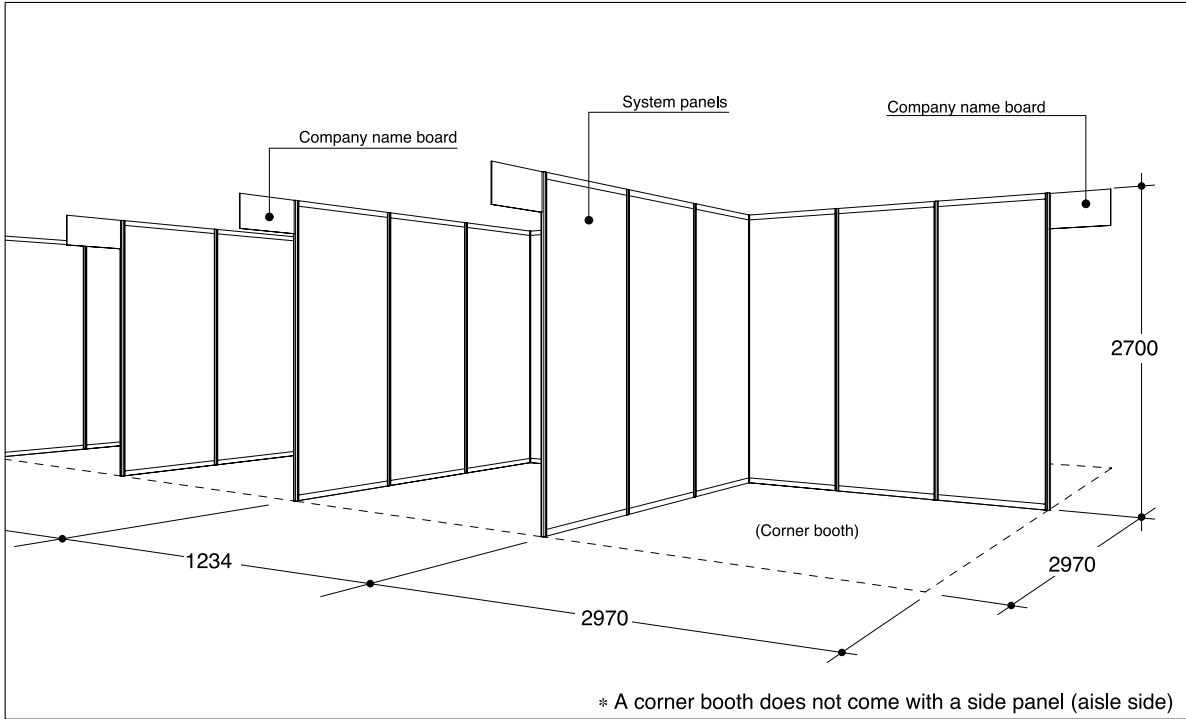

### ● Top View of Basic Booth

\*Measurements are from a center to a center of pillars.  
\*Unit : millimeters

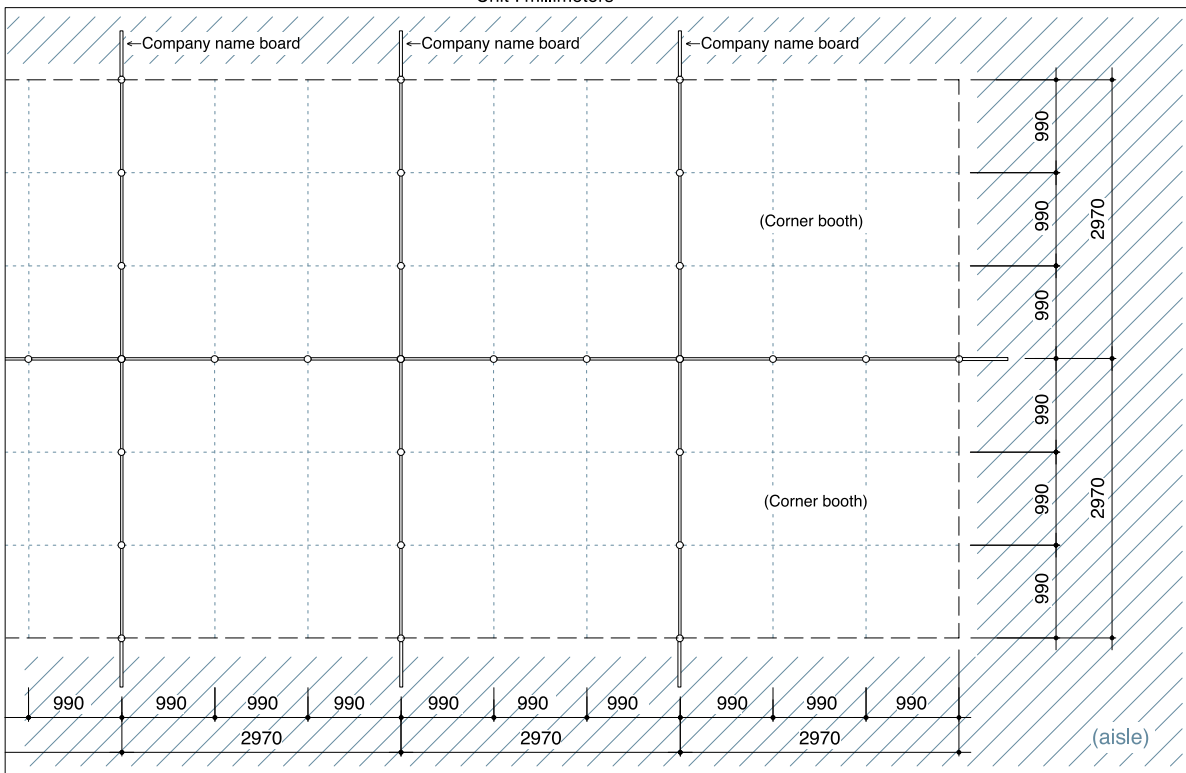

## ● Specifications of basic booth components

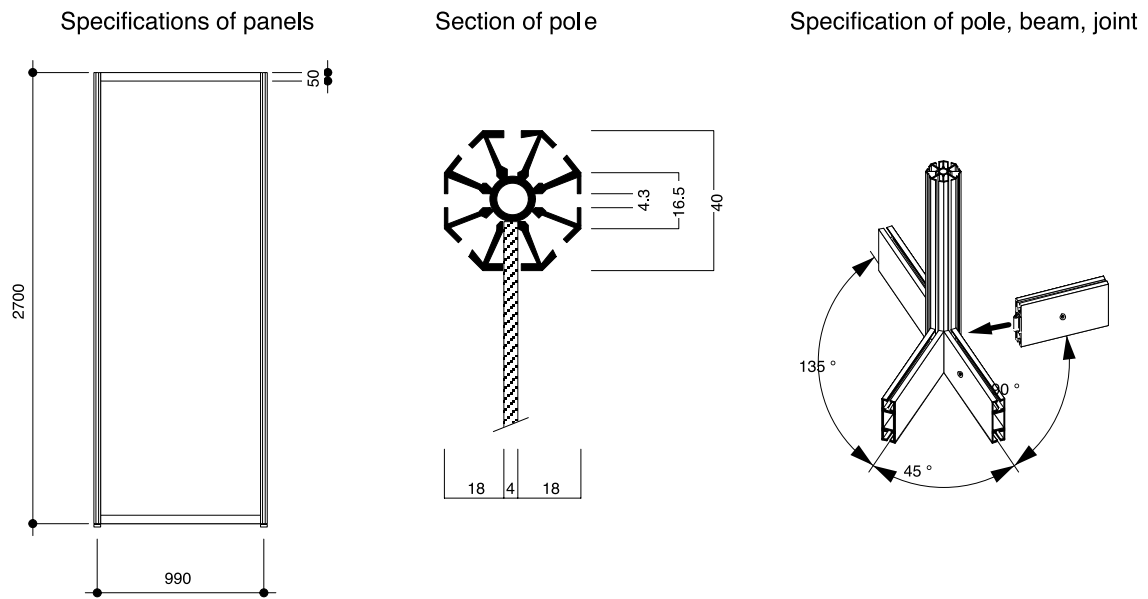

## ● Notes

- 1 System panels are composed of vinyl-coated plywood with white color.
- 2 Panels can be mounted with S-shaped hooks with chain and /or a Velcro tape.
- 3 System panels cannot be directly decorated or processed.
  - Nailing, cutting or making holes on the booth components (panel boards, beams, etc.) is strictly prohibited.
  - Neither pins nor a strong double-sided adhesive tape can be used.

## Packaged Booth Information

- ◆ All indicated prices and fees exclude applicable tax and entry fee.
- ◆ Unless specified, all listed prices and fees are subject to 10% consumption tax.
- ◆ Exhibitors willing to order one of the packaged booth plans (p.4-p.9) or optional tool(s) which requires electricity supply are requested to submit “Electrical work wiring diagram” in JASIS “Exhibit Service Manual (the manual)” as well as the order form(s) on p.15 & p.16 in this booklet. The manual is planned to be available in June on JASIS website.
- ◆ JASIS office issue electrical wiring to trunk line and electricity usage invoice after JASIS to exhibitors who ordered packaged booth plan or selected optional tool(s) which requires electricity supply. Please refer to the manual for detailed electric fees information.  
Note: Electrical wiring inside your booth such as placing outlets will be separately billed by designated booth contractor.
- ◆ Exhibitors using cabinet, a key for exclusive use is available upon request. Fee is JPY 700/each.

### ● Schedule

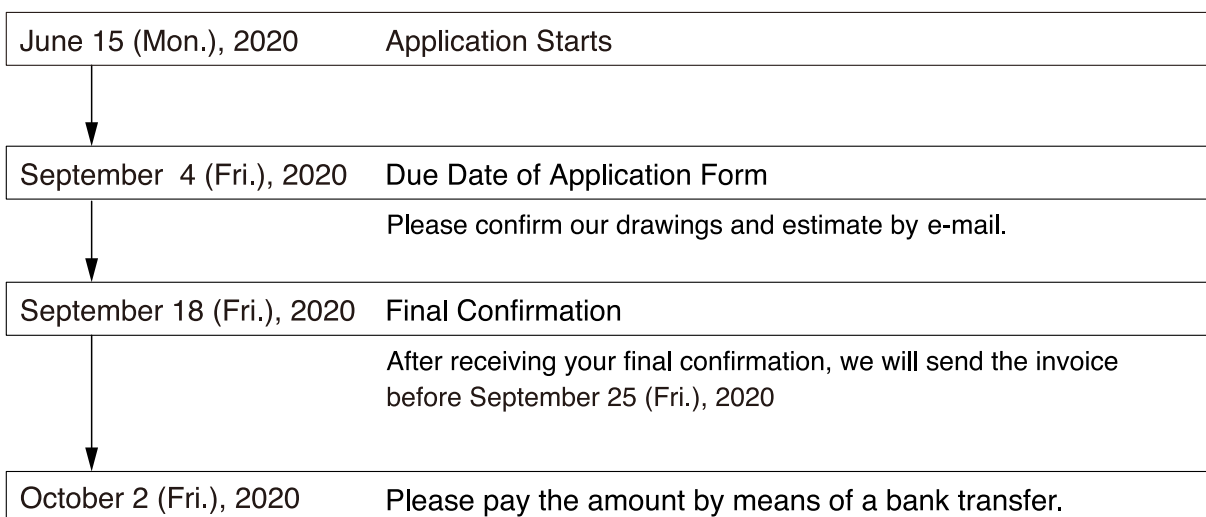

( The order for the construction of the booth will be placed when the full payment of the invoice has been made. We retain the right to reject the order if you fail to pay the invoice in full by the due date. Notwithstanding the above, we may accept such order at our option even if the full payment is delayed. In case of the acceptance of the order, the work schedule may be changed, if necessary, by discussion between the parties. )

For further information and request on “System Panel” and “Package Booth”, please contact the following company.

### **Ten Co.,LTD.**

Morimitu Shinkou Bldg.9F, 5-9, Kotobuki, 1-chome, Taitou-ku, Tokyo 111-0042, JAPAN

Fax : +81-3-3842-7720

E-mail : [jasis@teninc.co.jp](mailto:jasis@teninc.co.jp)

**★ I apologize for bothering you, but please contact us by E-mail.**

## ● Packaged Booth Display • 1 booth

### Packaged Booth Display 1-A

Total JPY41,100 (10% tax and entry fee excluded)

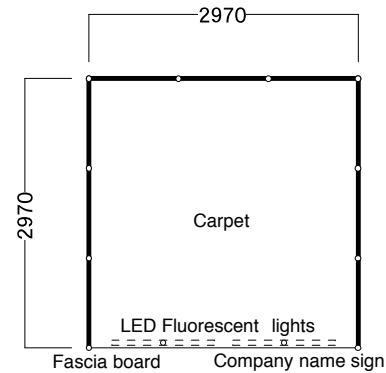
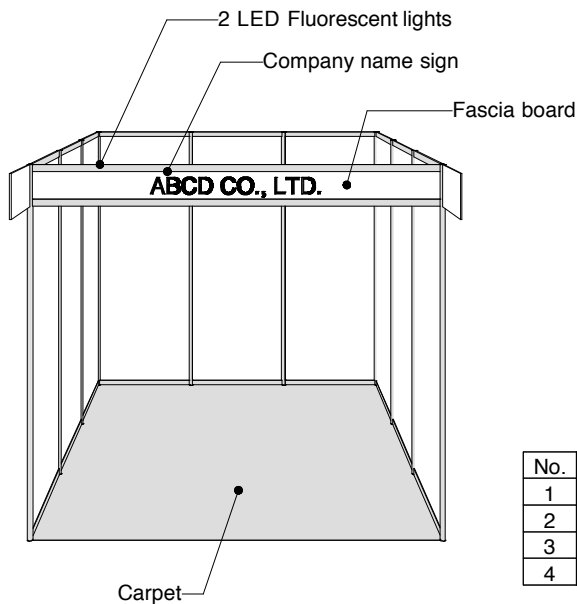

No.	Item	Notes	Q'ty
1	Fascia board		1
2	Company name sign	Font / Gothic Corner, Color / Black	1
3	LED Fluorescent lights	21W	2
4	Carpet	* Please refer to the color sample.	1

\* A corner booth comes with a header instead of side panel (aisle side).

\* All indicated prices exclude tax and entry fee. By ordering a packaged booth plan, you also obligate to submit "Electrical work wiring diagram form" in JASIS "Exhibit Service Manual" which is available on JASIS website in June; associated electrical wiring and usage fees are invoiced post JASIS.

### Packaged Booth Display 1-B

Total JPY79,580 (10% tax and entry fee excluded)

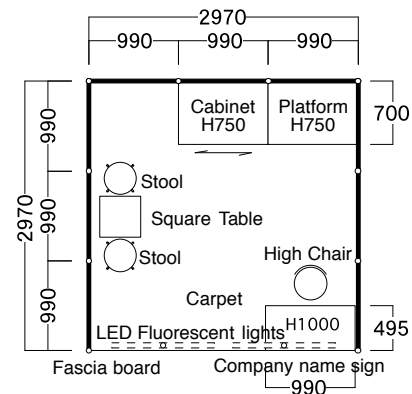
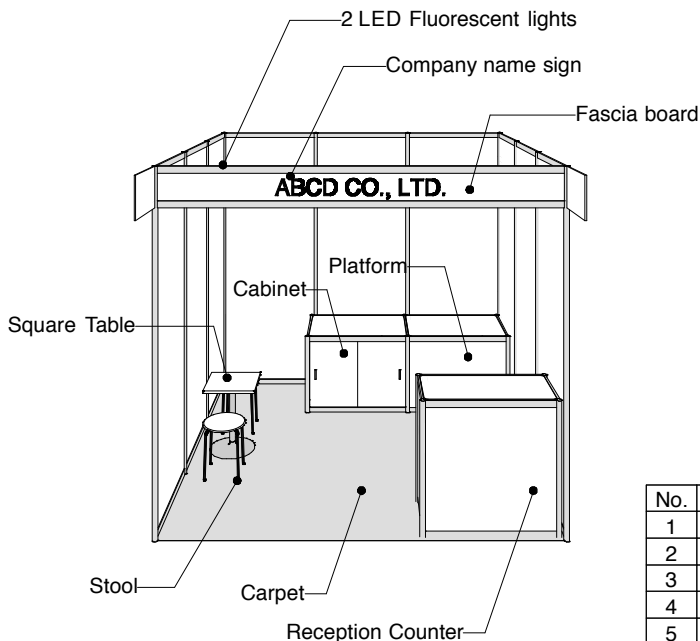

No.	Item	Notes	Q'ty
1	Fascia board		1
2	Company name sign	Font / Gothic Corner, Color / Black	1
3	LED Fluorescent lights	21W	2
4	Carpet	* Please refer to the color sample.	1
5	Platform	990*700*H750	1
6	Cabinet	990*700*H750	1
7	Reception Counter	990*495*H1000/ Ledged	1
8	High Chair		1
9	Square Table	450*450*H650	1
10	Stool		2

\* A corner booth comes with a header instead of side panel (aisle side).

\* The exclusive key for your cabinet is available at exhibitors' request.  
JPY700/ea

\* All indicated prices exclude tax and entry fee. By ordering a packaged booth plan, you also obligate to submit "Electrical work wiring diagram form" in JASIS "Exhibit Service Manual" which is available on JASIS website in June; associated electrical wiring and usage fees are invoiced post JASIS.

## ● Packaged Booth Display • 1 booth

### Packaged Booth Display 1-C

Total JPY81,500 (10% tax and entry fee excluded)

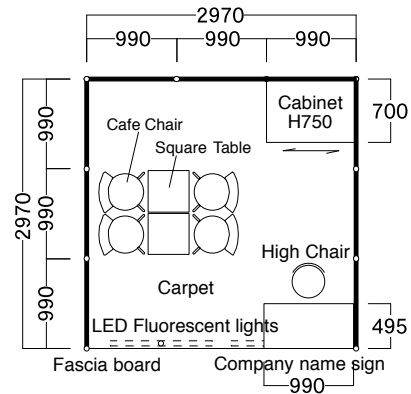
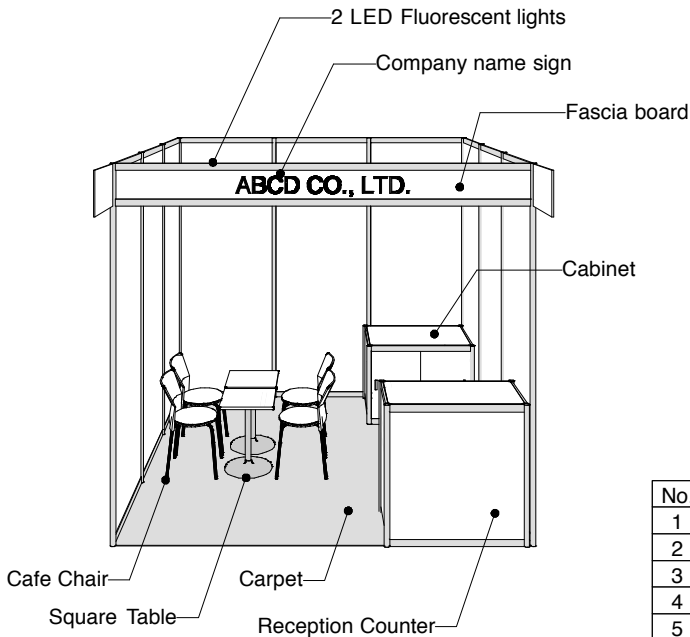

No.	Item	Notes	Q'ty
1	Fascia board		1
2	Company name sign	Font / Gothic Corner, Color / Black	1
3	LED Fluorescent lights	21W	2
4	Carpet	* Please refer to the color sample.	1
5	Cabinet	990*700*H750	1
6	Reception Counter	990*495*H1000/ Ledged	1
7	High Chair		1
8	Square Table	450*450*H650	2
9	Cafe Chair		4

- \* A corner booth comes with a header instead of side panel (aisle side).
  - \* The exclusive key for your cabinet is available at exhibitors' request.
- JPY700/ea

\* All indicated prices exclude tax and entry fee. By ordering a packaged booth plan, you also obligate to submit "Electrical work wiring diagram form" in JASIS "Exhibit Service Manual" which is available on JASIS website in June; associated electrical wiring and usage fees are invoiced post JASIS.

### Packaged Booth Display 1-D

Total JPY86,300 (10% tax and entry fee excluded)

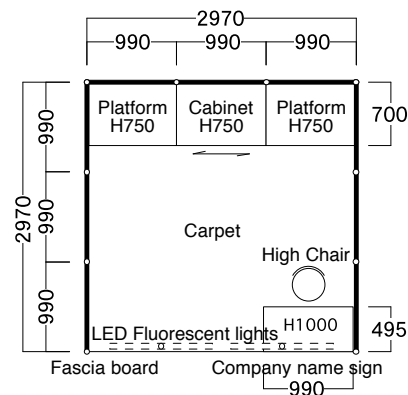
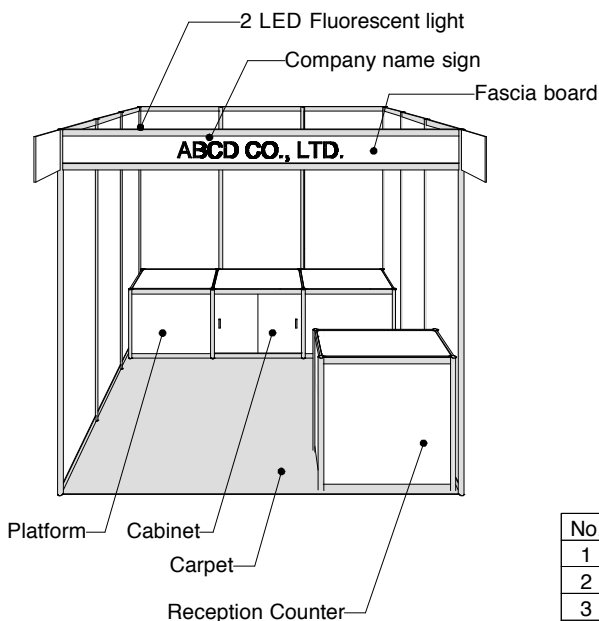

No.	Item	Notes	Q'ty
1	Fascia board		1
2	Company name sign	Font / Gothic Corner, Color / Black	1
3	LED Fluorescent lights	21W	2
4	Carpet	* Please refer to the color sample.	1
5	Platform	990*700*H750	2
6	Cabinet	990*700*H750	1
7	Reception Counter	990*495*H1000/ Ledged	1
8	High Chair		1

- \* A corner booth comes with a header instead of side panel (aisle side).
  - \* The exclusive key for your cabinet is available at exhibitors' request.
- JPY700/ea

\* All indicated prices exclude tax and entry fee. By ordering a packaged booth plan, you also obligate to submit "Electrical work wiring diagram form" in JASIS "Exhibit Service Manual" which is available on JASIS website in June; associated electrical wiring and usage fees are invoiced post JASIS.

## ● Packaged Booth Display • 2 booths

### Packaged Booth Display 2-A

Total JPY82,200 (10% tax and entry fee excluded)

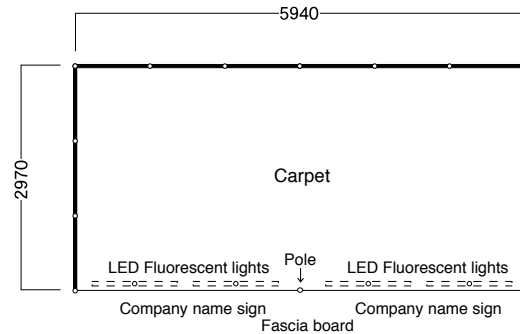
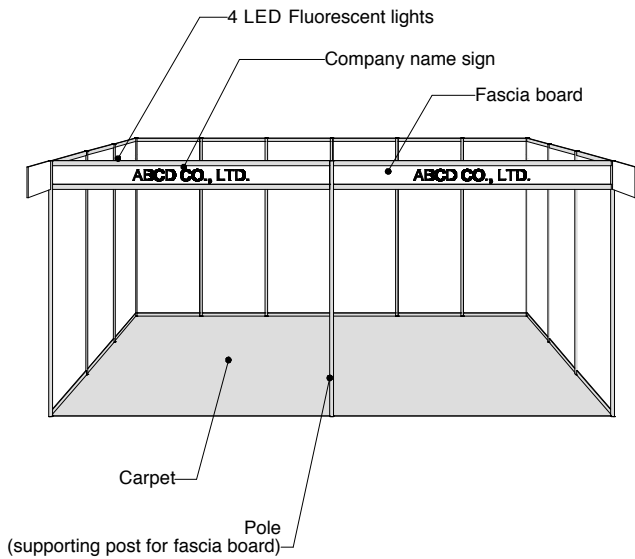

No.	Item	Notes	Q'ty
1	Fascia board		1
2	Pole	supporting post for fascia board	1
3	Company name sign	Font / Gothic Corner, Color / Black	2
4	LED Fluorescent lights	21W	4
5	Carpet	* Please refer to the color sample.	2

\* A corner booth comes with a header instead of side panel (aisle side).

\* All indicated prices exclude tax and entry fee. By ordering a packaged booth plan, you also obligate to submit "Electrical work wiring diagram form" in JASIS "Exhibit Service Manual" which is available on JASIS website in June; associated electrical wiring and usage fees are invoiced post JASIS.

### Packaged Booth Display 2-B

Total JPY169,600 (10% tax and entry fee excluded)

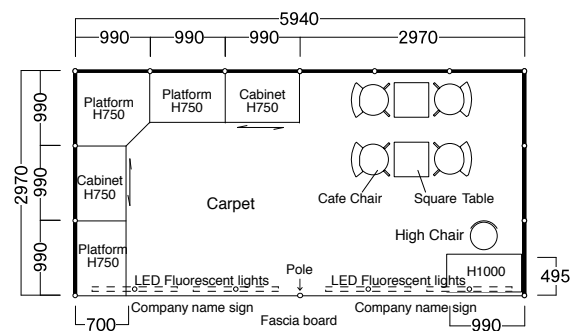
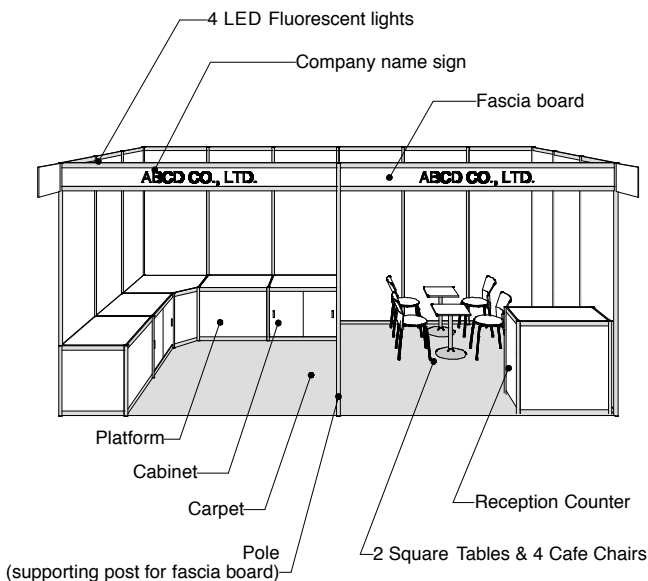

No.	Item	Notes	Q'ty
1	Fascia board		1
2	Pole	supporting post for fascia board	1
3	Company name sign	Font / Gothic Corner, Color / Black	2
4	LED Fluorescent lights	21W	4
5	Carpet	* Please refer to the color sample.	2
6	Platform	990*700*H750/2, 990*990*H750/1	3
7	Cabinet	990*700*H750	2
8	Reception Counter	990*495*H1000/ Ledge	1
9	High Chair		1
10	Square Table	450*450*H650	2
11	Cafe Chair		4

\* A corner booth comes with a header instead of side panel (aisle side).

\* The exclusive key for your cabinet is available at exhibitors' request.  
JPY700/ea

\* All indicated prices exclude tax and entry fee. By ordering a packaged booth plan, you also obligate to submit "Electrical work wiring diagram form" in JASIS "Exhibit Service Manual" which is available on JASIS website in June; associated electrical wiring and usage fees are invoiced post JASIS.

## ● Packaged Booth Display • 2 booths

### Packaged Booth Display 2-C

Total JPY188,400 (10% tax and entry fee excluded)

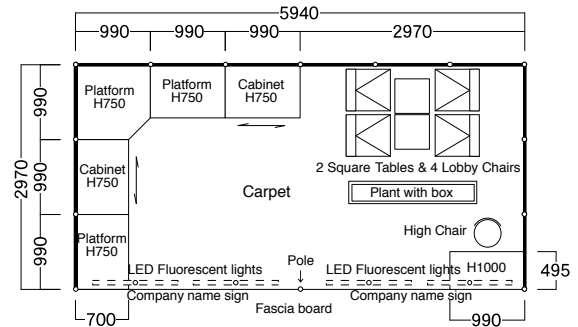
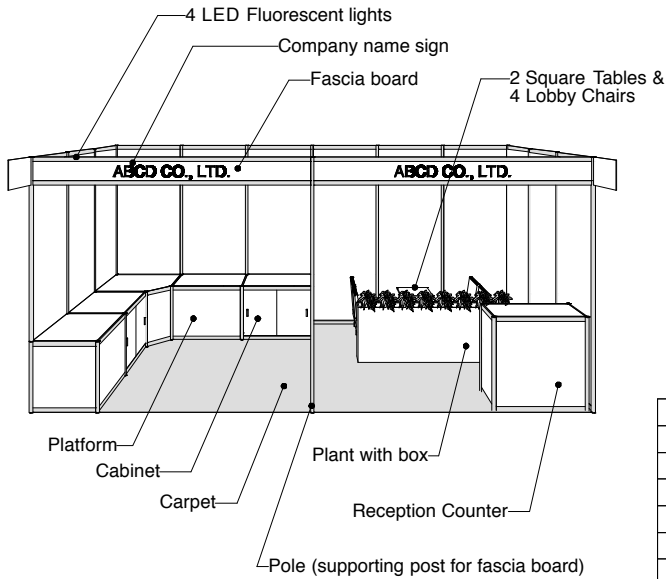

No.	Item	Notes	Q'ty
1	Fascia board		1
2	Pole	supporting post for fascia board	1
3	Company name sign	Font / Gothic Corner, Color / Black	2
4	LED Fluorescent lights	21W	4
5	Carpet	* Please refer to the color sample.	2
6	Platform	990*700*H750/2, 990*990*H750/1	3
7	Cabinet	990*700*H750	2
8	Reception Counter	990*495*H1000/ Ledged	1
9	High Chair		1
10	Square Table	450*450*H650	2
11	Lobby Chair		4
12	Plant with box	W1800	1

\* A corner booth comes with a header instead of side panel (aisle side).

\* The exclusive key for your cabinet is available at exhibitors' request.  
JPY700/ea

\* All indicated prices exclude tax and entry fee. By ordering a packaged booth plan, you also obligate to submit "Electrical work wiring diagram form" in JASIS "Exhibit Service Manual" which is available on JASIS website in June; associated electrical wiring and usage fees are invoiced post JASIS.

### Packaged Booth Display 2-D

Total JPY189,680 (10% tax and entry fee excluded)

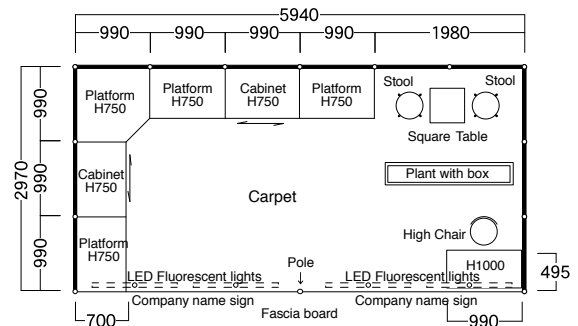
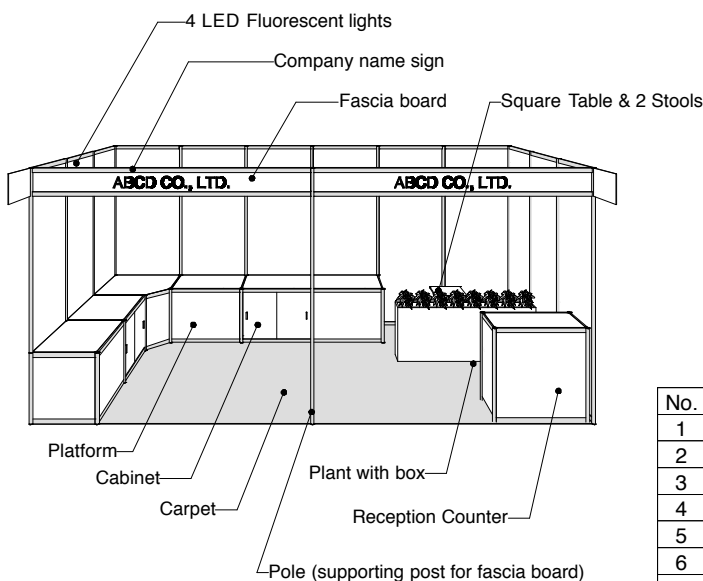

No.	Item	Notes	Q'ty
1	Fascia board		1
2	Pole	supporting post for fascia board	1
3	Company name sign	Font / Gothic Corner, Color / Black	2
4	LED Fluorescent lights	21W	4
5	Carpet	* Please refer to the color sample.	2
6	Platform	990*700*H750/3, 990*990*H750/1	4
7	Cabinet	990*700*H750	2
8	Reception Counter	990*495*H1000/ Ledged	1
9	High Chair		1
10	Square Table	450*450*H650	1
11	Stool		2
12	Plant with box	W1800	1

\* A corner booth comes with a header instead of side panel (aisle side).

\* The exclusive key for your cabinet is available at exhibitors' request.  
JPY700/ea

\* All indicated prices exclude tax and entry fee. By ordering a packaged booth plan, you also obligate to submit "Electrical work wiring diagram form" in JASIS "Exhibit Service Manual" which is available on JASIS website in June; associated electrical wiring and usage fees are invoiced post JASIS.



## ● Packaged Booth Display • 3 booths

### Packaged Booth Display 3-A

Total JPY123,300 (10% tax and entry fee excluded)

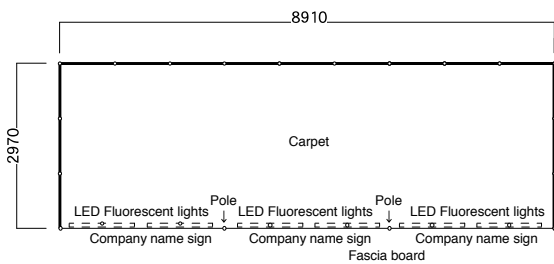
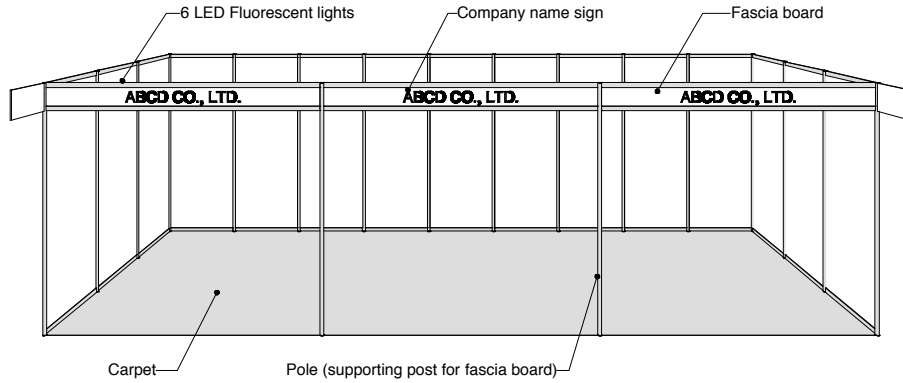

No.	Item	Notes	Q'ty
1	Fascia board		1
2	Pole	supporting post for fascia board	2
3	Company name sign	Font / Gothic Corner, Color / Black	3
4	LED Fluorescent lights	21W	6
5	Carpet	* Please refer to the color sample.	3

\* A corner booth comes with a header instead of side panel (aisle side).

\* All indicated prices exclude tax and entry fee. By ordering a packaged booth plan, you also obligate to submit "Electrical work wiring diagram form" in JASIS "Exhibit Service Manual" which is available on JASIS website in June; associated electrical wiring and usage fees are invoiced post JASIS.

### Packaged Booth Display 3-B

Total JPY265,200 (10% tax and entry fee excluded)

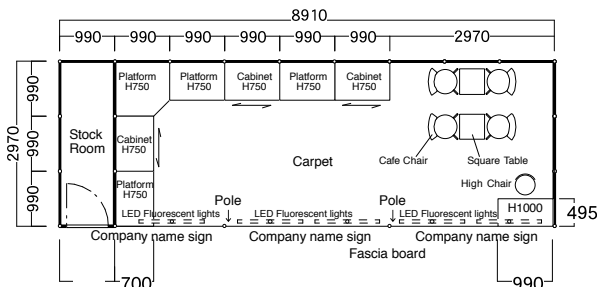
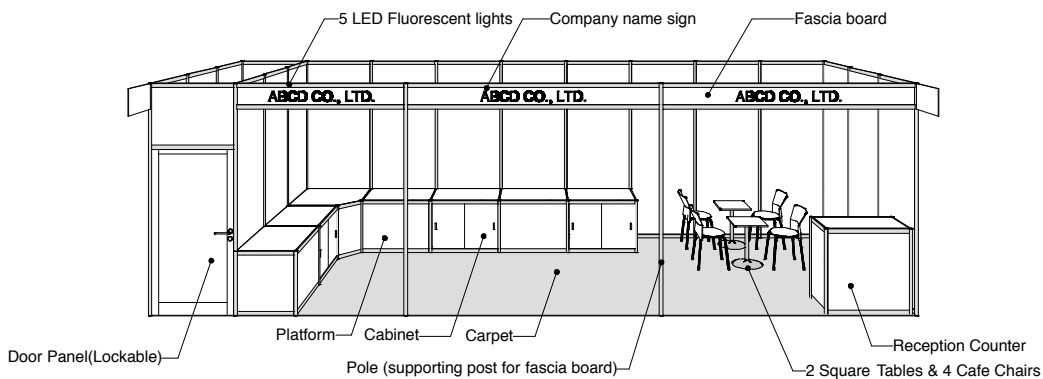

No.	Item	Notes	Q'ty
1	Fascia board		1
2	Pole	supporting post for fascia board	2
3	Company name sign	Font / Gothic Corner, Color / Black	3
4	LED Fluorescent lights	21W	5
5	Carpet	* Please refer to the color sample.	3
6	W990 Panel	H2700/Wall of Stock Room	3
7	Door Panel	W990*H2700 / Lockable	1
8	Platform	990*700*H750/3, 990*990*H750/1	4
9	Cabinet	990*700*H750	3
10	Reception Counter	990*495*H1000/ Ledge	1
11	High Chair		1
12	Square Table	450*450*H650	2
13	Cafe Chair		4

\* A corner booth comes with a header instead of side panel (aisle side).

\* The exclusive key for your cabinet is available at exhibitors' request.  
JPY700/ea

\* All indicated prices exclude tax and entry fee. By ordering a packaged booth plan, you also obligate to submit "Electrical work wiring diagram form" in JASIS "Exhibit Service Manual" which is available on JASIS website in June; associated electrical wiring and usage fees are invoiced post JASIS.

# ● Packaged Booth Display • 3 booths

## Packaged Booth Display 3-C

Total JPY270,060 (10% tax and entry fee excluded)

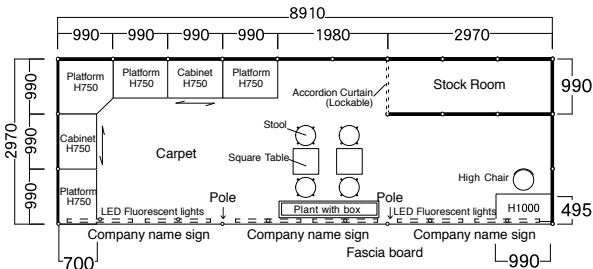
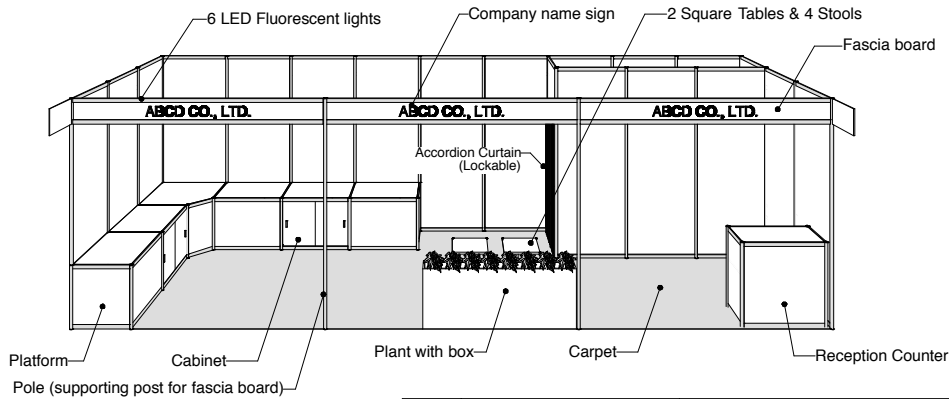

No.	Item	Notes	Q'ty
1	Fascia board		1
2	Pole	supporting post for fascia board	2
3	Company name sign	Font / Gothic Corner, Color / Black	3
4	LED Fluorescent lights	21W	6
5	Carpet	* Please refer to the color sample.	3
6	W990 Panel	H2700/Wall of Stock Room	3
7	Accordion Curtain	W990*H2700 / Lockable	1
8	Platform	990*700*H750/3, 990*990*H750/1	4
9	Cabinet	990*700*H750	2
10	Reception Counter	990*495*H1000/ Ledged	1
11	High Chair		1
12	Square Table	450*450*H650	2
13	Stool		4
14	Plant with box	W1800	1

- \* A corner booth comes with a header instead of side panel (aisle side).
- \* The exclusive key for your cabinet is available at exhibitors' request. JPY700/ea

\* All indicated prices exclude tax and entry fee. By ordering a packaged booth plan, you also obligate to submit "Electrical work wiring diagram form" in JASIS "Exhibit Service Manual" which is available on JASIS website in June; associated electrical wiring and usage fees are invoiced post JASIS.

## Packaged Booth Display 3-D

Total JPY284,000 (10% tax and entry fee excluded)

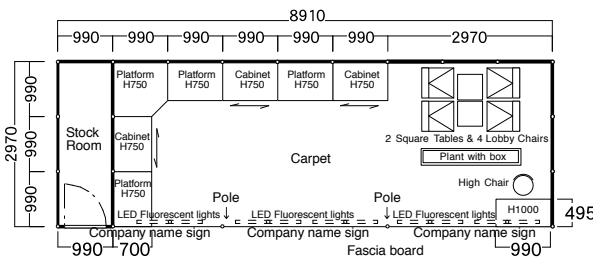
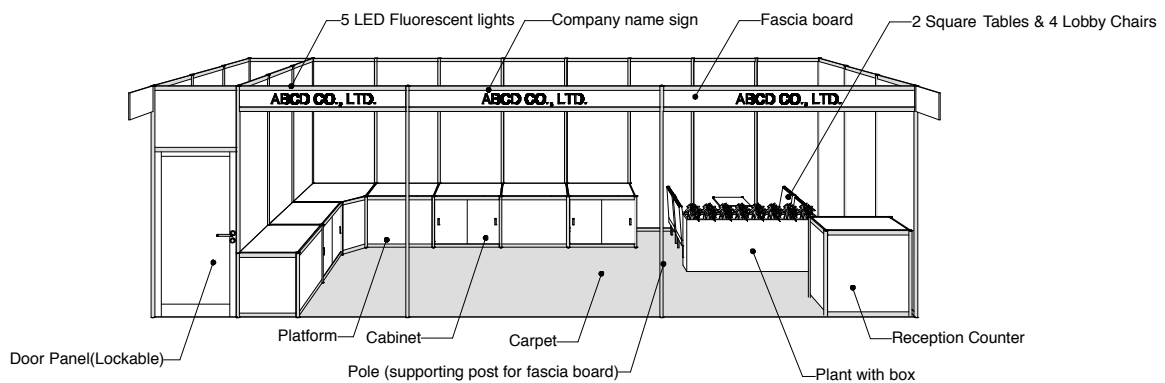

No.	Item	Notes	Q'ty
1	Fascia board		1
2	Pole	supporting post for fascia board	2
3	Company name sign	Font / Gothic Corner, Color / Black	3
4	LED Fluorescent lights	21W	5
5	Carpet	* Please refer to the color sample.	3
6	W990 Panel	H2700/Wall of Stock Room	3
7	Door Panel	W990*H2700 / Lockable	1
8	Platform	990*700*H750/3, 990*990*H750/1	4
9	Cabinet	990*700*H750	3
10	Reception Counter	990*495*H1000/ Ledged	1
11	High Chair		1
12	Square Table	450*450*H650	2
13	Lobby Chair		4
14	Plant with box	W1800	1

- \* A corner booth comes with a header instead of side panel (aisle side).
- \* The exclusive key for your cabinet is available at exhibitors' request. JPY700/ea

\* All indicated prices exclude tax and entry fee. By ordering a packaged booth plan, you also obligate to submit "Electrical work wiring diagram form" in JASIS "Exhibit Service Manual" which is available on JASIS website in June; associated electrical wiring and usage fees are invoiced post JASIS.

## ● Optional Tool ●

Option Tool 1-16

System parts

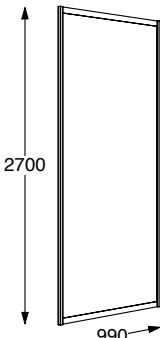
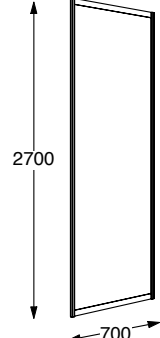
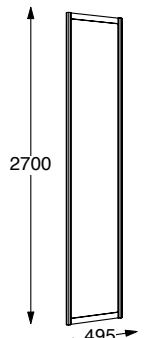
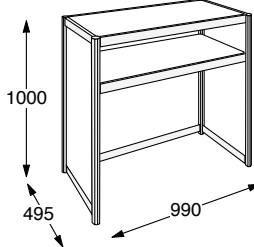
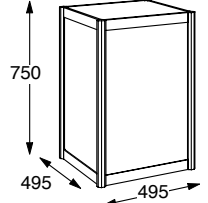
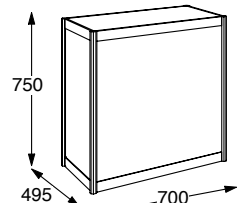
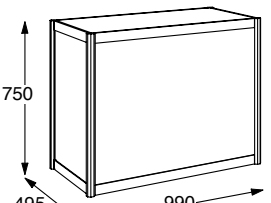
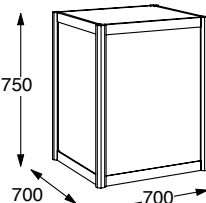
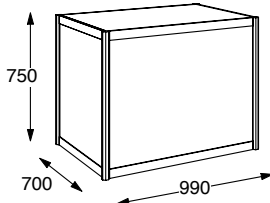
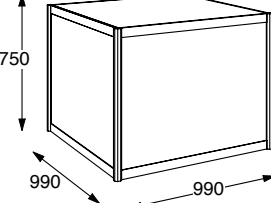
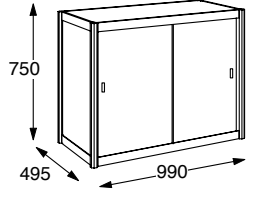
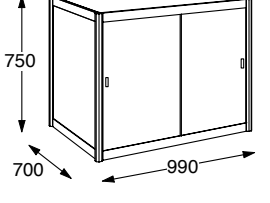
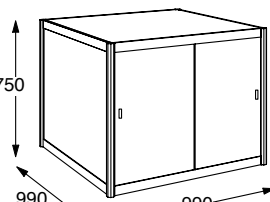
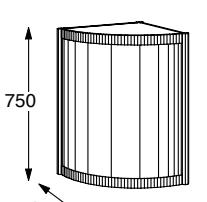
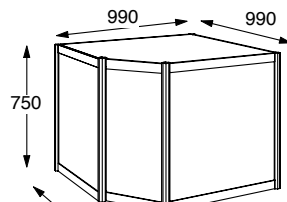
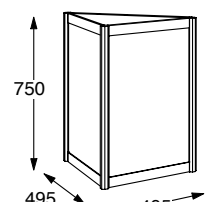
 <p>2700 990</p>	 <p>2700 700</p>	 <p>2700 495</p>	 <p>1000 495 990</p> <p>W990×D495×H1000</p>
<p><b>1</b> Wall Panel (W990) JPY6,000</p>	<p><b>2</b> Wall Panel (W700) JPY5,000</p>	<p><b>3</b> Wall Panel (W495) JPY5,000</p>	<p><b>4</b> Reception Counter JPY10,000</p>
<p>Withstand Load: 60kg</p>  <p>750 495 495</p> <p>W495×D495×H750</p>	<p>Withstand Load: 60kg</p>  <p>750 495 700</p> <p>W700×D495×H750</p>	<p>Withstand Load: 60kg</p>  <p>750 495 990</p> <p>W990×D495×H750</p>	<p>Withstand Load: 60kg</p>  <p>750 700 700</p> <p>W700×D700×H750</p>
<p><b>5</b> Display Platform JPY5,000</p>	<p><b>6</b> Display Platform JPY6,000</p>	<p><b>7</b> Display Platform JPY7,000</p>	<p><b>8</b> Display Platform JPY8,000</p>
<p>Withstand Load: 60kg</p>  <p>750 700 990</p> <p>W990×D700×H750</p>	<p>Withstand Load: 60kg</p>  <p>750 990 990</p> <p>W990×D990×H750</p>	<p>Withstand Load: 60kg</p>  <p>750 495 990</p> <p>W990×D495×H750</p>	<p>Withstand Load: 60kg</p>  <p>750 700 990</p> <p>W990×D700×H750</p>
<p><b>9</b> Display Platform JPY10,000</p>	<p><b>10</b> Display Platform JPY13,000</p>	<p><b>11</b> Cabinet JPY9,000</p>	<p><b>12</b> Cabinet JPY12,000</p>
<p>Withstand Load: 60kg</p>  <p>750 990 990</p> <p>W990×D990×H750</p>	<p>Withstand Load: 60kg</p>  <p>750 495 495</p> <p>W495×D495×H750</p>	<p>Withstand Load: 60kg</p>  <p>990 990 750 700 700</p> <p>W990×D990×H750</p>	<p>Withstand Load: 60kg</p>  <p>750 495 495</p> <p>W495×D495×H750</p>
<p><b>13</b> Cabinet JPY15,000</p>	<p><b>14</b> 495R Display Platform JPY7,000</p>	<p><b>15</b> Corner Display Platform JPY15,000</p>	<p><b>16</b> 495L Display Platform JPY5,000</p>

\* The exclusive key for your cabinet is available at exhibitors' request. JPY700/ea

● Optional Tool ●









Option Tool 17-32

System parts/etc.

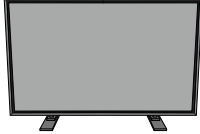
 <p>2700 990 Lockable</p>	 <p>2700 990</p>	 <p>2700 990 Lockable</p>	 <p>300 990</p>
<p><b>17</b> Accordion Curtain JPY18,000</p>	<p><b>18</b> Acrylic Panel JPY20,000</p>	<p><b>19</b> Door Panel JPY20,000</p>	<p><b>20</b> Shelf Board JPY3,500</p>
 <p>300</p>		 <p>900 900 Hooks (No. 22) included</p>	 <p>W1200×D600×H940</p>
<p><b>21</b> Fascia Board JPY2,500/m</p>	<p><b>22</b> Hooks for Mesh Panel ( 4 ) JPY1,000</p>	<p><b>23</b> Mesh panel JPY6,000</p>	<p><b>24</b> Counter unit (with shelves inside) JPY10,000</p>
 <p>(A4-size, 12 racks)</p>	 <p>(A4-size, 3 racks)</p>		 <p>W1800×D600×H730</p>
<p><b>25</b> Catalogue Rack JPY5,600</p>	<p><b>26</b> Desk-top Catalogue Rack JPY1,600</p>	<p><b>27</b> Fire Extinguisher JPY4,000</p>	<p><b>28</b> Table JPY3,200</p>
 <p>W600×D600×H650</p>	 <p>Ø750×H650</p>		
<p><b>29</b> Square Table JPY2,000</p>	<p><b>30</b> Round Table JPY4,000</p>	<p><b>31</b> Folding Chair JPY640</p>	<p><b>32</b> Stacking Chair JPY3,200</p>

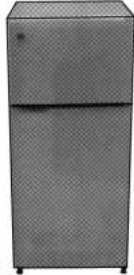
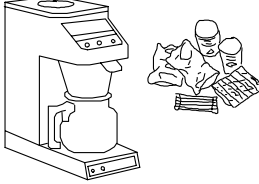
● Optional Tool ●

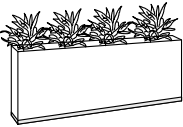
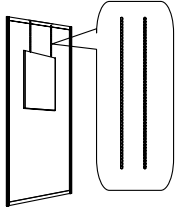
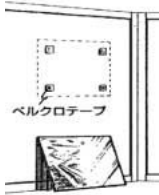
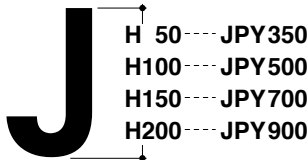

Option Tool 33-48 Rental

			 <p>The Self-standing tabletop (Video and Personal computer support) Body (1920×1080 pixels) equipped with speaker. Body size : W973×H566×D126 / ≈22kg Body size with stands : W973×H602×D270 / ≈24kg * The cost includes the rental fee for 3 days, the transportation fee, and the adjustment fee. * There is the case that the specifications may be different from the original because of the lack of the stocks. * There will be the additional charge for installation to wall. Please apply for 100V outlet (225W) separately.</p>																																				
<p><b>33</b> High Chair JPY3,200</p>	<p><b>34</b> Reception Room Furniture Set JPY10,000</p>	<p><b>35</b> Name Card Box JPY1,600</p>	<p><b>36</b> 42" Wide-LCD JPY81,000</p>																																				
 <p>W900×D450×H1800</p>	 <p>(Middle size: 100 lit.) Please apply for 100V outlet (100W) separately.</p>	 <p>The coffee maker and the coffee beans, sugar, creams, paper cups, and stirrers for 100 people Please apply for 100V outlet (1.5kW) separately.</p>																																					
<p><b>37</b> Steel shelf JPY6,000</p>	<p><b>38</b> Refrigerator JPY16,000</p>	<p><b>39</b> The Coffee Maker &amp; The Coffee Set JPY23,600</p>	<p><b>40</b> Planter(Large) JPY3,500</p>																																				
	 <p>W1800 JPY22,000 W1300 JPY16,000 W 900 JPY11,000</p>	<table border="1"> <tbody> <tr><td>Red</td><td>No.P-1</td></tr> <tr><td>Dark blue</td><td>No.P-2</td></tr> <tr><td>Green</td><td>No.P-3</td></tr> <tr><td>Dark gray</td><td>No.P-4</td></tr> <tr><td>Orange</td><td>No.P-5</td></tr> <tr><td>Blue</td><td>No.P-6</td></tr> <tr><td>Light gray</td><td>No.P-7</td></tr> <tr><td>Yellowish green</td><td>No.P-8</td></tr> </tbody> </table> <p>* Please refer to the color sample.</p>	Red	No.P-1	Dark blue	No.P-2	Green	No.P-3	Dark gray	No.P-4	Orange	No.P-5	Blue	No.P-6	Light gray	No.P-7	Yellowish green	No.P-8	<table border="1"> <tbody> <tr><td>Cream</td><td>No.1</td></tr> <tr><td>Yellow</td><td>No.2</td></tr> <tr><td>Pink</td><td>No.3</td></tr> <tr><td>Red</td><td>No.4</td></tr> <tr><td>Light blue</td><td>No.5</td></tr> <tr><td>Blue</td><td>No.6</td></tr> <tr><td>Mint green</td><td>No.7</td></tr> <tr><td>Green</td><td>No.8</td></tr> <tr><td>Black</td><td>No.9</td></tr> <tr><td>Grain pattern</td><td>No.10</td></tr> </tbody> </table> <p>■ Monotint JPY5,500/span ■ Pattern JPY7,200/span * 1span=W990×H2700 * Please refer to the color sample.</p>	Cream	No.1	Yellow	No.2	Pink	No.3	Red	No.4	Light blue	No.5	Blue	No.6	Mint green	No.7	Green	No.8	Black	No.9	Grain pattern	No.10
Red	No.P-1																																						
Dark blue	No.P-2																																						
Green	No.P-3																																						
Dark gray	No.P-4																																						
Orange	No.P-5																																						
Blue	No.P-6																																						
Light gray	No.P-7																																						
Yellowish green	No.P-8																																						
Cream	No.1																																						
Yellow	No.2																																						
Pink	No.3																																						
Red	No.4																																						
Light blue	No.5																																						
Blue	No.6																																						
Mint green	No.7																																						
Green	No.8																																						
Black	No.9																																						
Grain pattern	No.10																																						
<p><b>41</b> Planter(Small) JPY1,000</p>	<p><b>42</b> Flower box</p>	<p><b>43</b> Carpet (Needle punched carpet) JPY2,400/m<sup>2</sup></p>	<p><b>44</b> Coloring for Wall</p>																																				
<p>To hung up the explanation panel, graphic panel, and so on</p>  <p>For one panel One set has two s-shaped hooks with chain.</p>  <p>For one panel One set has four Velcro tapes of 3sq mm.</p>		 <p>H 50----JPY350 H100----JPY500 H150----JPY700 H200----JPY900</p> <p>* Black Letter (unified font) (When you have preferred color or logo, please contact us by e-mail.)</p>	 <p>W900×H150</p> <p>* Styrene Board/Black Letter (unified font) (When you have preferred color or logo, please contact us by e-mail.)</p>																																				
<p><b>45</b> S-shaped hooks with chain JPY600</p>	<p><b>46</b> Velcro tape. JPY600</p>	<p><b>47</b> Cutting Letters</p>	<p><b>48</b> Company Name Plate JPY4,000</p>																																				

## ● Optional Tool ●

Option Tool 49–54

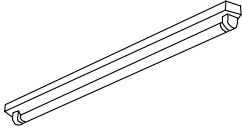
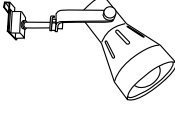
Rental

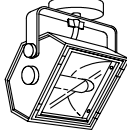
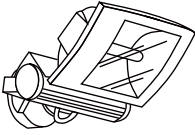
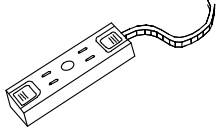
<p>* Wiring fee for trunk line and electricity charge are required separately.</p>  <p>(21W)</p>	<p>* Wiring fee for trunk line and electricity charge are required separately.</p>  <p>(11W)</p>	<p>* Wiring fee for trunk line and electricity charge are required separately.</p>  <p>(11W)</p>	<p>* Wiring fee for trunk line and electricity charge are required separately.</p>  <p>(300W)</p>										
<p><b>49</b> LED Fluorescent Light <b>JPY3,000</b></p>	<p><b>50</b> LED Spot Light <b>JPY3,000</b></p>	<p><b>51</b> LED Spot Light with Arm <b>JPY3,500</b></p>	<p><b>52</b> Halogen Lamp <b>JPY7,000</b></p>										
<p>* Wiring fee for trunk line and electricity charge are required separately.</p>  <p>(70W)</p>	<p>* Wiring fee for trunk line and electricity charge are required separately.</p>  <p>★ Please indicate the capacity. (Maximum is 1.5kW per an outlet.) <b>Please let us know if you would like 200V outlet</b></p>	<p>The following construction fee of the electric panel boards will be required if the total electrical capacity exceeds over 1500W. (The fluorescent lamps in the package booth are included.)</p> <table border="1" data-bbox="833 974 1158 1131"> <thead> <tr> <th>Total Capacity</th> <th>Fee for Distribution Panel</th> </tr> </thead> <tbody> <tr> <td>less than 1,500W</td> <td>not necessary</td> </tr> <tr> <td>over 1,501W under 3,000W</td> <td>JPY6,000</td> </tr> <tr> <td>over 3,001W under 4,500W</td> <td>JPY9,000</td> </tr> <tr> <td colspan="2">★ Over 3000W, it is charged 3,000 yen every additional 1,500W</td> </tr> </tbody> </table>		Total Capacity	Fee for Distribution Panel	less than 1,500W	not necessary	over 1,501W under 3,000W	JPY6,000	over 3,001W under 4,500W	JPY9,000	★ Over 3000W, it is charged 3,000 yen every additional 1,500W	
Total Capacity	Fee for Distribution Panel												
less than 1,500W	not necessary												
over 1,501W under 3,000W	JPY6,000												
over 3,001W under 4,500W	JPY9,000												
★ Over 3000W, it is charged 3,000 yen every additional 1,500W													
<p><b>53</b> HID 70W <b>JPY9,400</b></p>	<p><b>54</b> 100V Outlet <b>JPY2,500</b></p>												

※ By ordering an optional tool on this page, you also obligate to submit “Electrical work wiring diagram” in JASIS “Exhibit Service Manual” which is available on JASIS website in June; associated electrical wiring and usage fees are invoiced post JASIS.

● Color Sample ●

System Panels

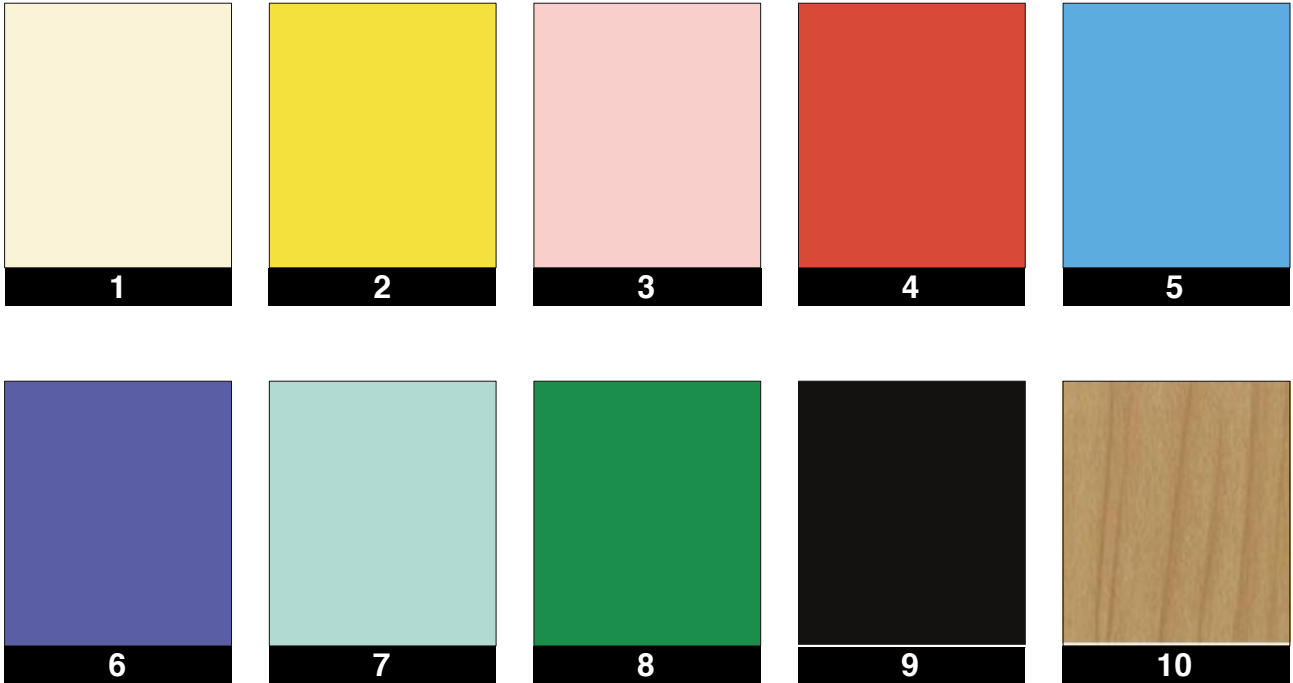

Carpet (Needle punched carpet)

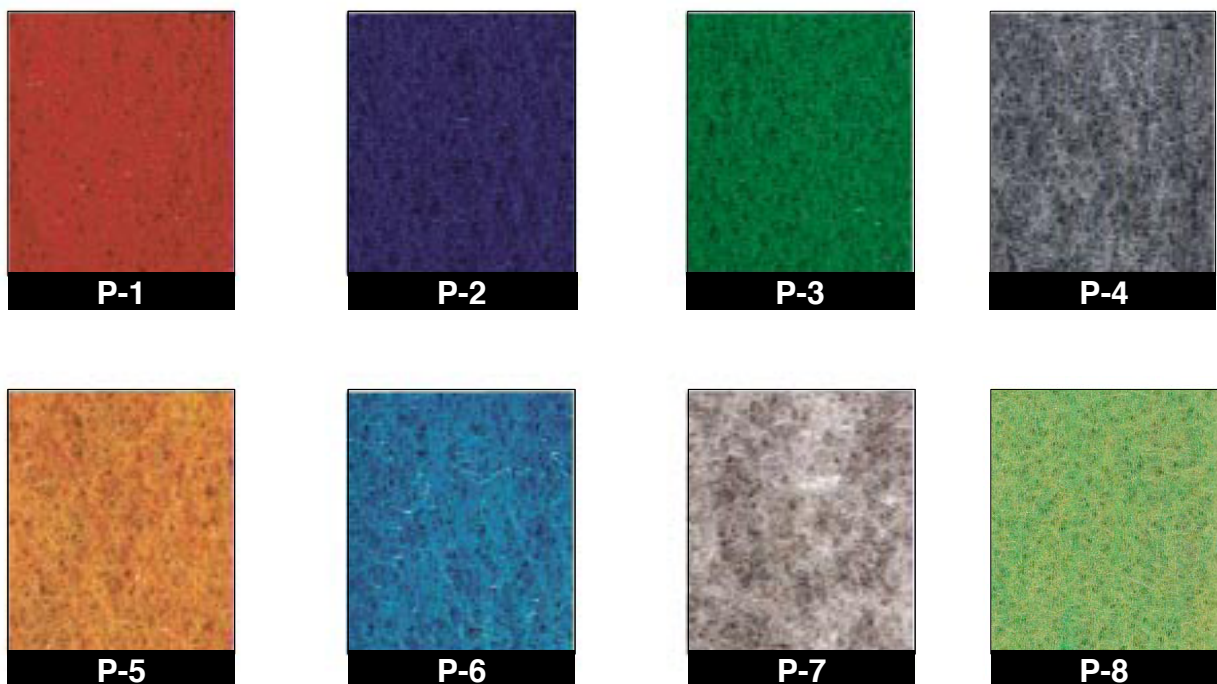

# Packaged Booth Display Order Form

[ Application Starts : June 15 (Mon.), 2020 ] [ Due Date : September 4 (Fri.), 2020 ]



Application date : (Month) (Day), 2020

Booth No.			
Company Name			
Department		Person in Charge	
Address	-----		
TEL		FAX	
E-mail			

◆ Circle the No. of the packaged booth which you would like to order.

No.	Packaged Booth Display	Price
1	Packaged Booth Display 1-A (1 booth)	JPY41,100 (10% tax and entry fee excluded)
2	Packaged Booth Display 1-B (1 booth)	JPY79,580 (10% tax and entry fee excluded)
3	Packaged Booth Display 1-C (1 booth)	JPY81,500 (10% tax and entry fee excluded)
4	Packaged Booth Display 1-D (1 booth)	JPY86,300 (10% tax and entry fee excluded)
5	Packaged Booth Display 2-A (2 booths)	JPY82,200 (10% tax and entry fee excluded)
6	Packaged Booth Display 2-B (2 booths)	JPY169,600 (10% tax and entry fee excluded)
7	Packaged Booth Display 2-C (2 booths)	JPY188,400 (10% tax and entry fee excluded)
8	Packaged Booth Display 2-D (2 booths)	JPY189,680 (10% tax and entry fee excluded)
9	Packaged Booth Display 3-A (3 booths)	JPY123,300 (10% tax and entry fee excluded)
10	Packaged Booth Display 3-B (3 booths)	JPY265,200 (10% tax and entry fee excluded)
11	Packaged Booth Display 3-C (3 booths)	JPY270,060 (10% tax and entry fee excluded)
12	Packaged Booth Display 3-D (3 booths)	JPY284,000 (10% tax and entry fee excluded)

\* All indicated prices exclude tax and entry fee. By ordering a packaged booth plan, you also obligate to submit "Electrical work wiring diagram form" in JASIS "Exhibit Service Manual" which is available on JASIS website in June; associated electrical wiring and usage fees are invoiced post JASIS.

◆ Selection of the color of the carpet 《Mandatory》

Circle the color No. of the carpet which you would like to order. \*Please refer to the color sample

No.	P-1	P-2	P-3	P-4	P-5	P-6	P-7	P-8
-----	-----	-----	-----	-----	-----	-----	-----	-----

◆ Put a check mark in the box below depending on necessity.

In addition to the above packaged booth, we would like to order optional tools.

(When you put a check mark in the above box, please fill in the attached "Optional Tool Order Form" )

Submit order form to	<p><b>Ten Co.,LTD.</b>                  Address: Morimitu Shinkou Bldg.9F,5-9, Kotobuki 1-chome, Taitou-ku, Tokyo 111-0042 Japan                  Fax : +81-3-3842-7720 E-mail : jasis@teninc.co.jp                  ★ I apologize for bothering you, but please contact us by E-mail</p>
----------------------	---



Optional Tool Order Form

[ Due Date : September 4 (Fri.), 2020 ]

Booth No.	Company Name		
Address			FAX
Department	Person in Charge	E-mail	
Submit order form to	<b>Ten Co.,LTD.</b> Address : Morimitu Shinkou Bldg.9F,5-9, Kotobuki 1-chome,Taitou-ku, Tokyo 111-0042 Japan Fax : +81-3-3842-7720 E-mail : jasis@teninc.co.jp		

- If you also submit the attached "Packaged Booth Display Order Form", put a check mark in the box at right. →→→
- Please indicate preferable location of each item and the capacity and location of outlet when using the electrical power supply.

	<p>[ Layout Example ]</p>
--	---------------------------

Option items

No.	Items	Q'ty	Price	Charge	Note
1	Wall Panel (W990xH2700)		6,000		
2	Wall Panel (W700xH2700)		5,000		
3	Wall Panel (W495xH2700)		5,000		
4	Reception Counter (W990xD495xH1000)		10,000		
5	Display Platform (W495xD495xH750)		5,000		
6	Display Platform (W700xD495xH750)		6,000		
7	Display Platform (W990xD495xH750)		7,000		
8	Display Platform (W700xD700xH750)		8,000		
9	Display Platform (W990xD700xH750)		10,000		
10	Display Platform (W990xD990xH750)		13,000		
11	Cabinet (W990xD495xH750)		9,000		
12	Cabinet (W990xD700xH750)		12,000		
13	Cabinet (W990xD990xH750)		15,000		
14	495R Display Platform (W495xD495xH750)		7,000		
15	Corner Display Platform (W990xD990xH750)		15,000		
16	495L Display Platform (W495xD495xH750)		5,000		
17	Accordion Curtain		18,000		
18	Acrylic Panel		20,000		
19	Door Panel (Lockable)		20,000		
20	Shelf Board (W990xD300)		3,500		
21	Fascia Board	m	2,500		
22	Hooks for Mesh Panel ( 4 )	Set	1,000		
23	Mesh panel (W900xH900)		6,000		Hooks (No. 22) included
24	Counter unit (W1200xD600xH940)		10,000		(with shelves inside)
25	Catalogue Rack (A4-size, 12 racks)		5,600		
26	Desk-top Catalogue Rack (A4-size, 3 racks)		1,600		
27	Fire Extinguisher		4,000		
28	Table (W1800xD600xH730)		3,200		
29	Square Table (W600xD600xH650)		2,000		
30	Round Table (Ø750xH650)		4,000		
31	Folding Chair		640		
32	Stacking Chair		3,200		
33	High Chair		3,200		
34	Reception room Furniture Set	Set	10,000		
35	Name Card Box		1,600		
36	42" Wide-LCD		81,000		
37	Steel shelf (W900xD450xH1800)		6,000		
38	Refrigerator (Middle size: 100 lit.)		16,000		
39	The Coffee Maker & The Coffee Set		23,600		
40	Planter (Large)		3,500		
41	Planter (Small)		1,000		
42	Flower box W1800		22,000		
42	Flower box W1300		16,000		
42	Flower box W900		11,000		
43	Carpet ( Needle punched carpet )	m <sup>2</sup>	2,400		Color (No. : )
44	Coloring for Wall (Monotint)	span	5,500		Color (No. : )
44	Coloring for Wall (Grain Pattern)	span	7,200		No .10
45	S-shaped hooks with chain		600		
46	Velcro tape		600		
47	Cutting Letters H50	letter	350		
47	Cutting Letters H100	letter	500		
47	Cutting Letters H150	letter	700		
47	Cutting Letters H200	letter	900		
48	Company Name Plate (W900xH150)		4,000		
49	LED Fluorescent Light (21W)		3,000		
50	LED Spot Light (11W)		3,000		
51	LED Spot Light with Arm (11W)		3,500		
52	Halogen Lamp (300W)		7,000		
53	HID (70W)		9,400		
54	100V Outlet		2,500		electric capacity ( W )
<b>Total</b>					

\* All indicated prices exclude tax and entry fee. By ordering an optional tool which requires electricity supply, you also obligate to submit "Electrical work wiring diagram form" in JASIS "Exhibit Service Manual" which is available on JASIS website in June; associated electrical wiring and usage fees are invoiced post JASIS.